

# Monitoring of marine environment disasters using CFOSAT, HY Series and multiple satellites data (ID: 59310) Abstract

Jianqiang Liu<sup>1,2</sup>, Ying Xu<sup>1,2</sup>, Daniele Hauser<sup>3</sup>, Jing Ding<sup>1,2</sup>,  
Qingjun Song<sup>1,2</sup>, Tao Zeng<sup>1,2</sup>, Chao Liang<sup>1,2</sup>, Maohua Guo<sup>1,2</sup>,  
Xiuzhong Li<sup>4</sup>, Wenming Lin<sup>4</sup>, Lingling Xie<sup>5</sup>, François Schmitt<sup>6</sup>

- <sup>1</sup>(National Satellite Ocean Application Service, MNR, Beijing, China)
- <sup>2</sup>(Key Laboratory of Space Ocean Remote Sensing and Application, MNR)
- <sup>3</sup>(CNRS/LATMOS, Guyancourt, France)
- <sup>4</sup>(Nanjing University of Information Science & Technology, Nanjing, China)
- <sup>5</sup>(Guangdong Ocean University, Zhanjiang, China)
- <sup>6</sup>(CNRS/Laboratory of Oceanology and Geosciences, Wimereux, France)

The China France Oceanography Satellite (CFOSAT) and Haiyang-2B (HY-2B) satellites were successively launched in China in 2018. As missions for measuring the dynamic marine environment, both satellites can measure the nadir significant wave height (SWH). In this project, the HY-2B altimeter and CFOSAT nadir SWHs have been validated against the National Data Buoy Center (NDBC) buoys and the Jason-3 altimeter SWH data, respectively, which resulted in CFOSAT nadir SWH having the best accuracy and HY-2B having the best precision. The SWHs of the two missions are also calibrated by Jason-3 and NDBC buoys. Following calibration, the root mean square error (RMSE) of CFOSAT and HY-2B are 0.21 and 0.27 m, respectively, when compared to Jason-3, and 0.23 and 0.30 m, respectively, compared to the buoys. Our results show that the two missions can provide good-quality SWH and can be relied upon as a new data resource of global SWH.

Using simultaneous observations of wind and wave fields by the CFOSAT, this project reports preliminary investigation results of the typhoon waves during the passage of super typhoon Lingling (2019) over the China offshore waters. The results show that the significant wave heights (SWHs) are over 5 m on the right side of the typhoon track for wind speeds over  $14 \text{ m s}^{-1}$ , agreeing with the theoretical estimates. The dominant waves have wavelengths of 150 – 180 m, and propagate eastward for northwestward blowing winds. The misalignments of the wind and wave directions increase with the distance from the typhoon center, agreeing with theoretical prediction. We also present the typhoon monitoring results with multiple satellites such as CFOSAT, HY-2B and ASCAT.

HY-1D satellite which is China's fourth series of ocean color satellites, was successfully launched in 2020. The overall objective of HY-1 serial satellite is to monitor global ocean color and SST (Sea Surface Temperature), as well as the coastal zones' environment. Using HY-1 C/D data and Sentinel satellite data, this project investigates the sea ice, oil spill and green tide disaster in Bohai Sea and the Yellow Sea, red tide in East China Sea. The results show that combining HY-1 C/D and Sentinel satellite data have played an important role in ocean ecological disaster monitoring.



# Monitoring of marine environment disasters using CFOSAT, HY Series and multiple satellites data (59310)

Jianqiang Liu<sup>1,2</sup>, Ying Xu<sup>1,2</sup>, Daniele Hauser<sup>3</sup>, Jing Ding<sup>1,2</sup>, Qingjun Song<sup>1,2</sup>, Maohua Guo<sup>1,2</sup>, Tao Zeng<sup>1,2</sup>, Xiuzhong Li<sup>4</sup>, Wenming Lin<sup>4</sup>, Lingling Xie<sup>5</sup>, François Schmitt<sup>6</sup>

<sup>1</sup>(National Satellite Ocean Application Service, MNR, Beijing, China) ,

<sup>2</sup>(Key Laboratory of Space Ocean Remote Sensing and Application, MNR)

<sup>3</sup>(CNRS/LATMOS, Guyancourt, France) ,<sup>4</sup>(Nanjing University of Information Science & Technology, Nanjing, China)

<sup>5</sup>(Guangdong Ocean University, Zhanjiang, China) <sup>6</sup>(CNRS/Laboratory of Oceanology and Geosciences ,Wimereux, France)



国家卫星海洋应用中心  
National Satellite Ocean Application Service



LARA  
Key Laboratory of Space Ocean Remote Sensing and Application, MNR



LATMOS

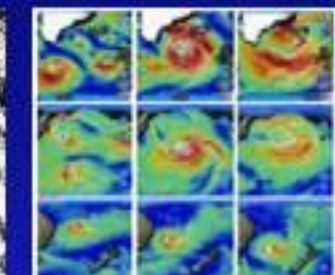

# Out line

- 1. Background and proposal**
- 2. CFOSAT /HY-1/HY-2/GF-3 Sentinel**
- 3. Validation of CFOSAT and multiple satellite data**
- 4. Validation and merging of HY-1 and multiple satellite data**
- 5. Monitoring of marine dynamics and marine environment disasters with multiple satellite**
- 6. Next Plan**

# 1 Background and proposal

- **As global climate change intensifies, many countries are facing increasing marine environment disasters. These disasters, such as typhoons, giant waves, macro algal blooms and decrease in sea ice cover pose a serious threat to coastal areas, aquaculture and maritime transportation. Therefore, it is essential for governments to respond quickly and reduce the loss and damage of these disasters.**
- **Satellite observation plays an important role in monitoring these marine environmental disasters by its unique advantages. However, monitoring of marine disasters with a single satellite data is extremely difficult due to the limitations of observed parameters, resolution, and revisit time etc. Consequently, utilization of multiple satellites data is inevitable and superior.**

# 1 Background and proposal

- **Taking advantage of the multiple satellites data such as CFOSAT, HY-1, HY-2 and multiple satellites, this proposal aims to provide the combined satellite monitoring of marine environment disasters. Three aspects of research will be carried out.**
  - **Firstly, the validation of CFOSAT and multiple satellite data will be executed.**
  - **Secondly, the validation and merging of HY-1 and multiple satellite data will be executed.**
  - **Thirdly, the multiple satellite data are combined to present the monitoring results of marine environment disasters. Meanwhile, data processing methods regarding the above three aspects, interactions of observed parameters and evolution mechanisms of marine environment disasters will also be investigated.**
- **This proposal has across subjects in Marine Disasters & Coastal zones including algae and phytoplankton blooms, marine dynamic environment and marine disasters.**



culture + technical standard +manage



# 3 Validation of CFOSAT and multiple satellite data

## CFOSAT Mission

Chinese wind scatterometer (SCAT)

**Ocean surface wind vector**

French wave spectrometer (SWIM)

**Directional spectrum of ocean surface waves**

**Nadir wind and Hs**

**Launch 2018.10.29**

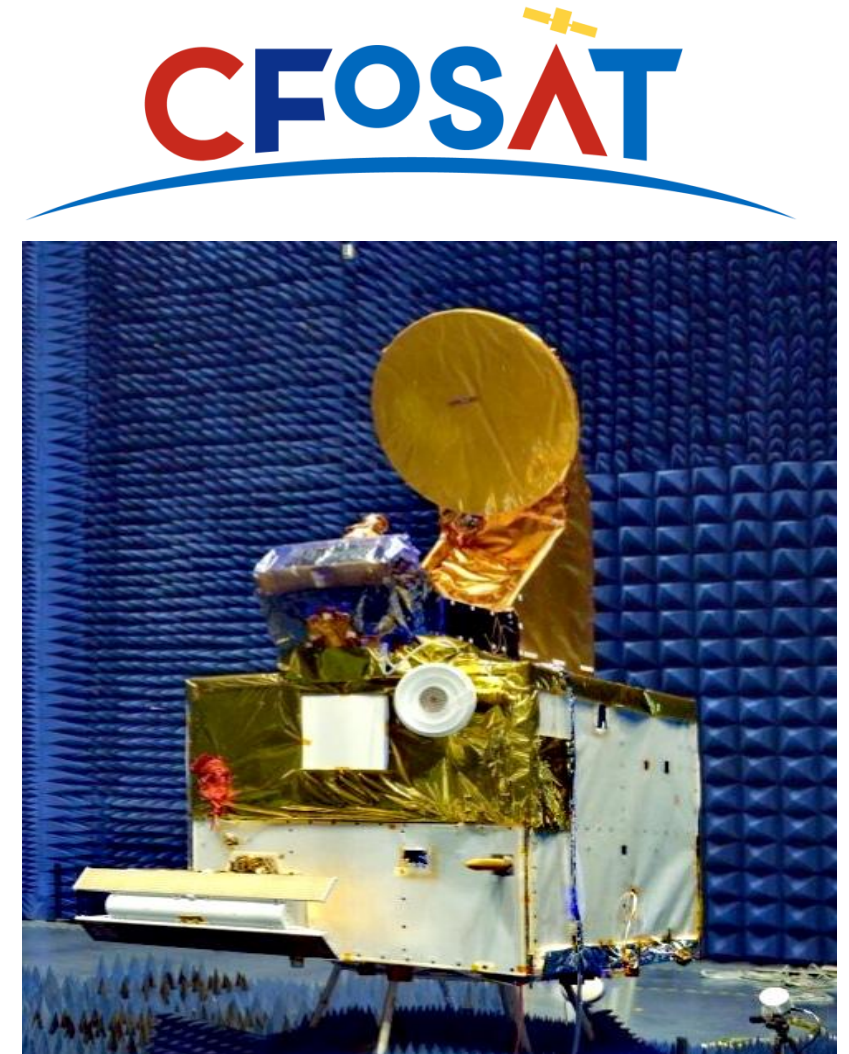





## Chinese wind scatterometer (SCAT)

### ➤ Provides

- $\sigma_0$
- Ocean wind vector at the scale :  
12.5 km x 12.5 km/25 km x 25 km
- Swath ~ 1000 km

### ➤ Expected accuracy:

- Wind speed           2 m/s,
- Wind direction       15°

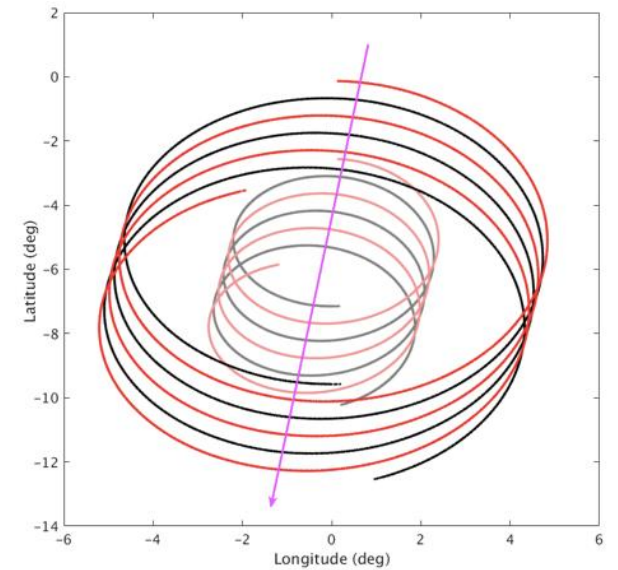
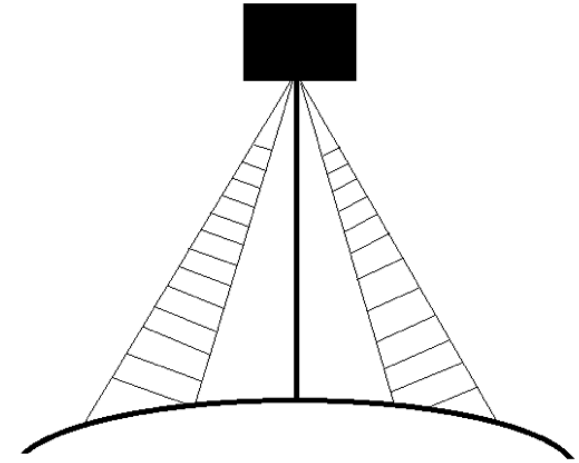
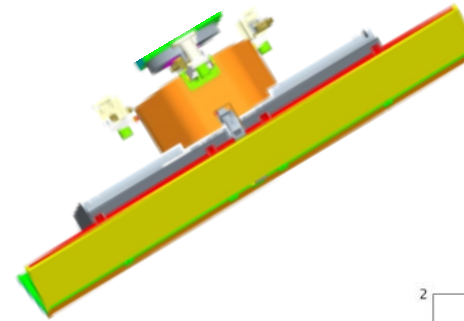

## 海面风场全球分布专题图

(20190207T00:09:07 UTC -- 20190207T23:52:44 UTC)

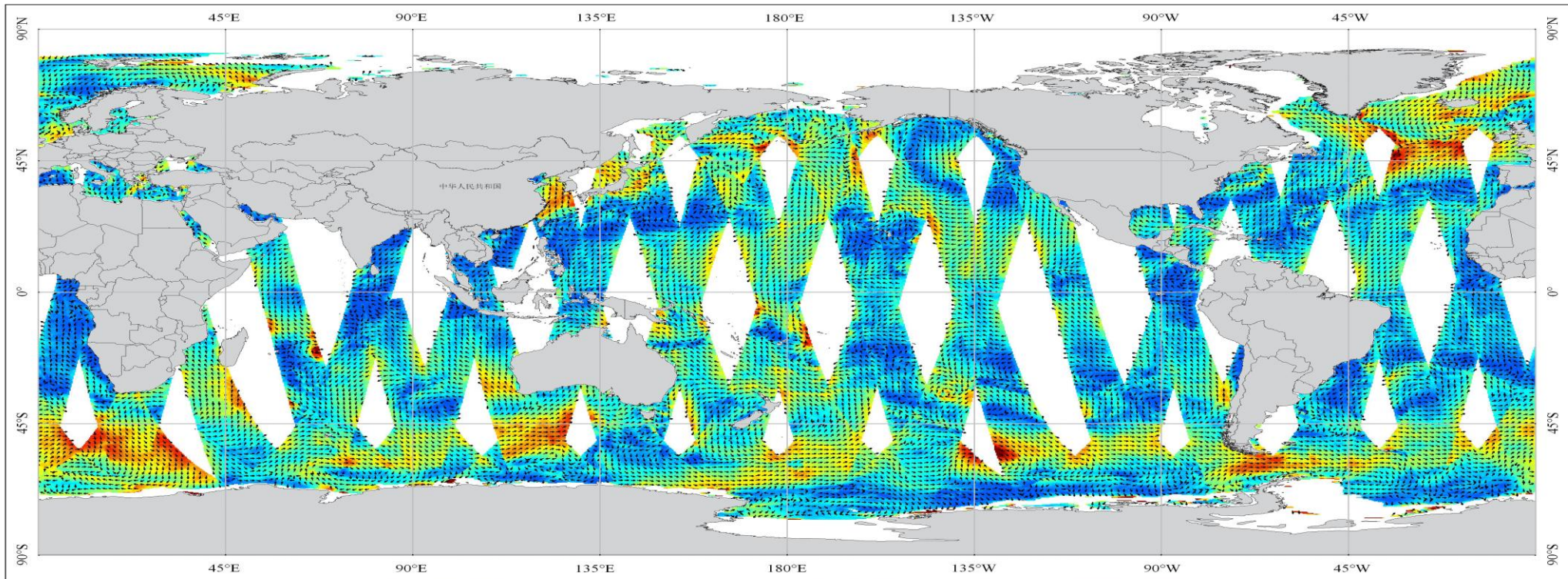

制图单位：国家卫星海洋应用中心

制图时间：2019年02月08日

坐标系：CGCS2000

比例尺：1:100,000,000

卫星名称：CFOSAT

传感器：微波散射计



## French wave spectrometer(SWIM)

➤ Provides :

- Directional wave spectra
- Significant wave height and wind speed
- $\sigma_0$  mean profiles, 0 to  $10^\circ$

➤ Expected accuracy:

- Energy error  $\leq 15\%$ ,
- Wavelength error  $\leq 10\text{-}20\%$  (70 - 500m)
- Azimuth error  $\leq 15^\circ$
- Nadir SWH  $\text{max}(10\%, 50 \text{ cm})$
- Nadir Wind Speed  $\text{max}(10\%, 2 \text{ m/s})$

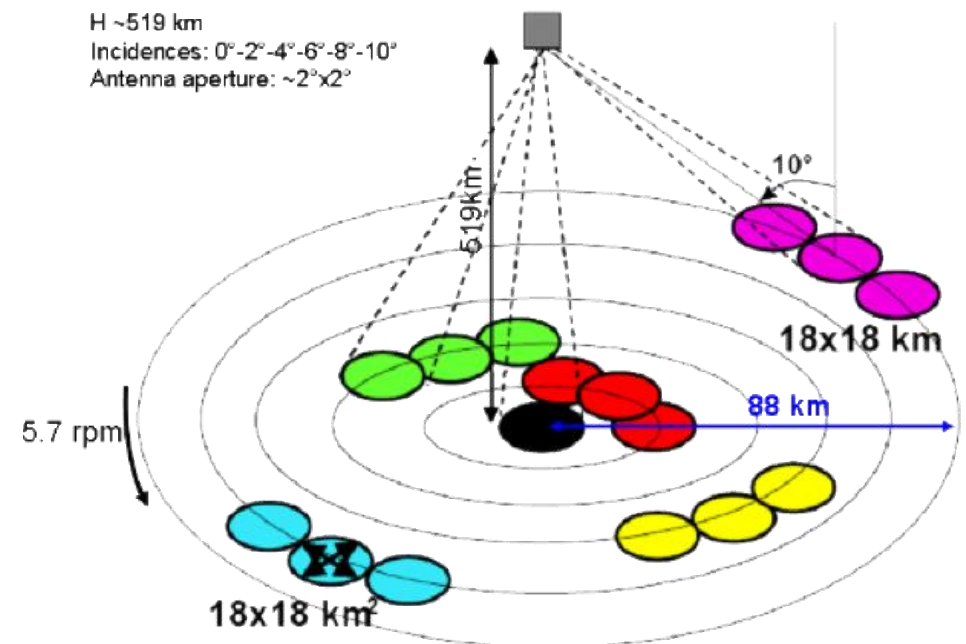
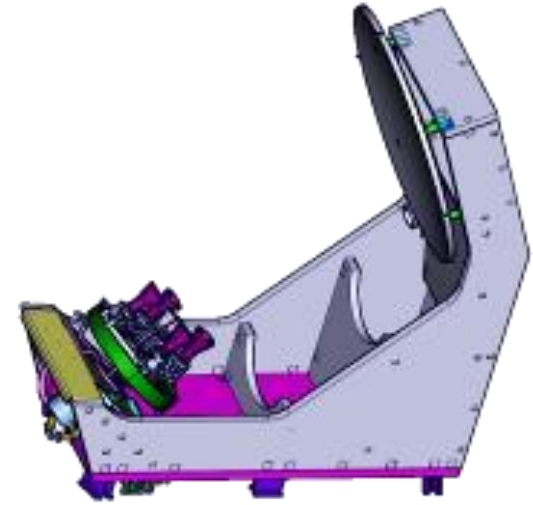



CFOSAT Significant Wave Height  
(20190501T000001 – 20190507T235959)

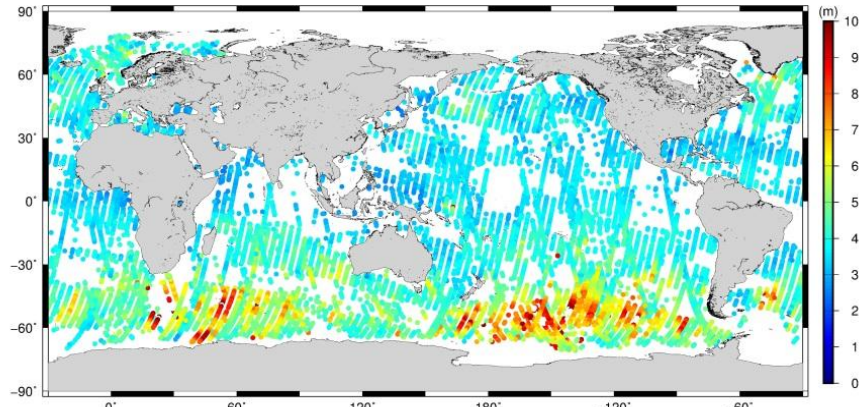

CFOSAT Peak Wavelength  
(20190501T000001 – 20190507T235959)

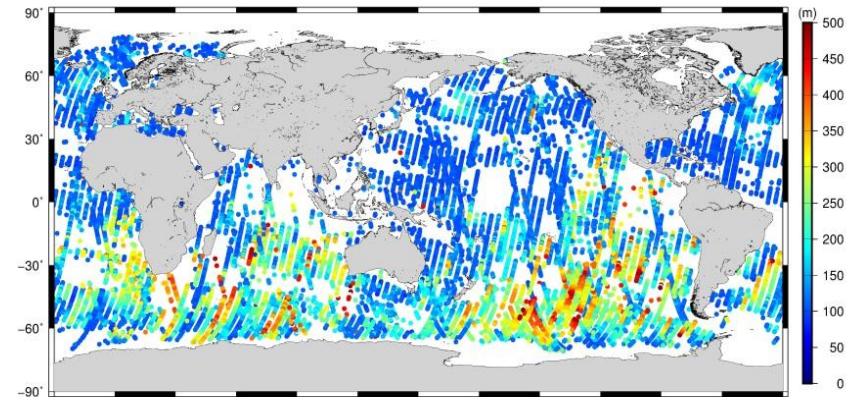

CFOSAT Peak Wave Direction  
(20190501T000001 – 20190507T235959)

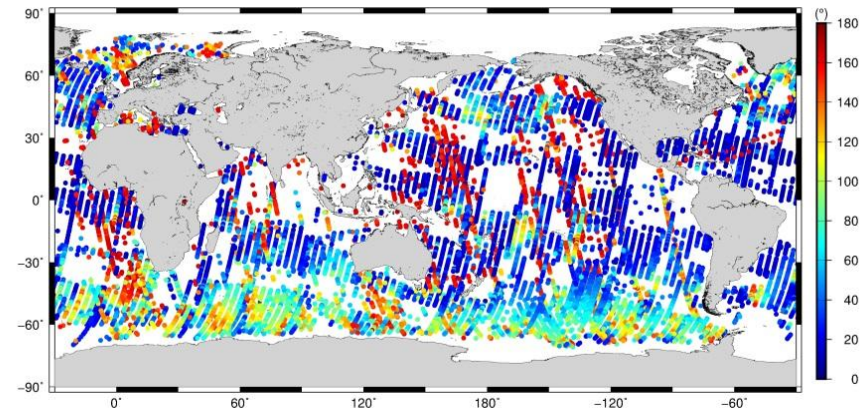

CFOSAT SWI\_L4A Significant Wave Height  
(20190501T000001 – 20190501T235959)

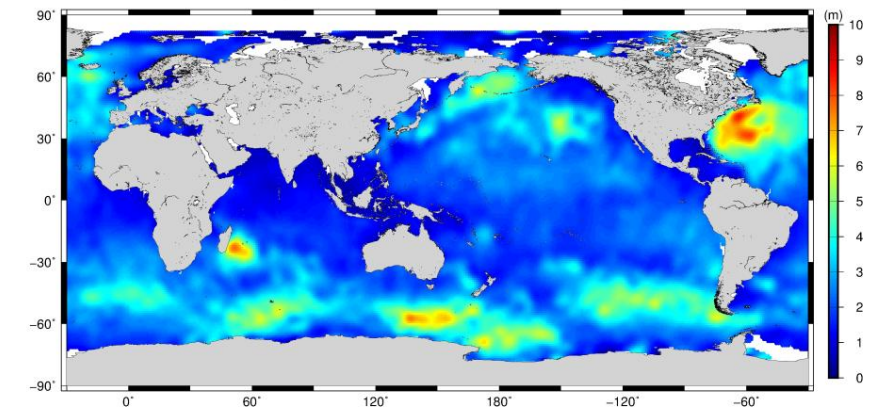



## 2D Wave Sprectrum

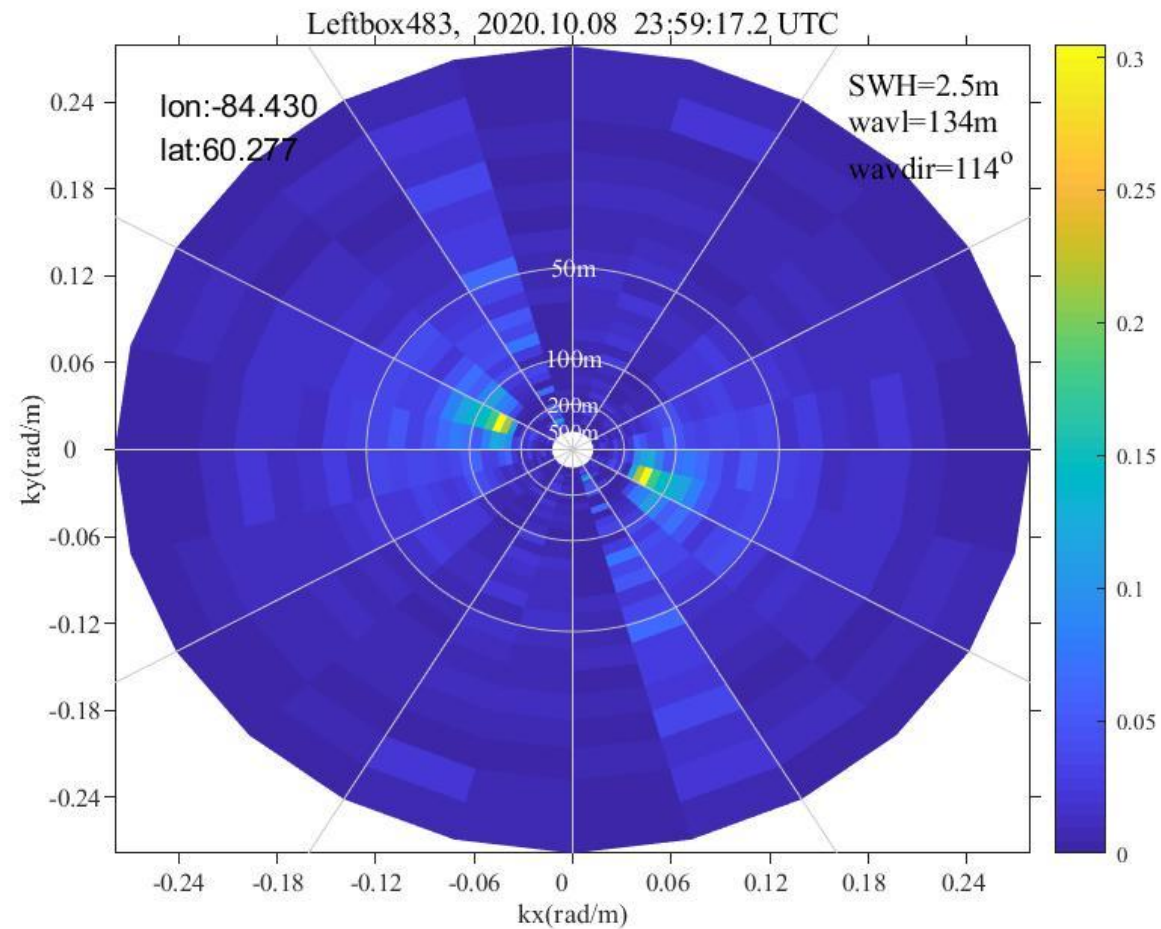



## Nadir SWH Precision Analysis

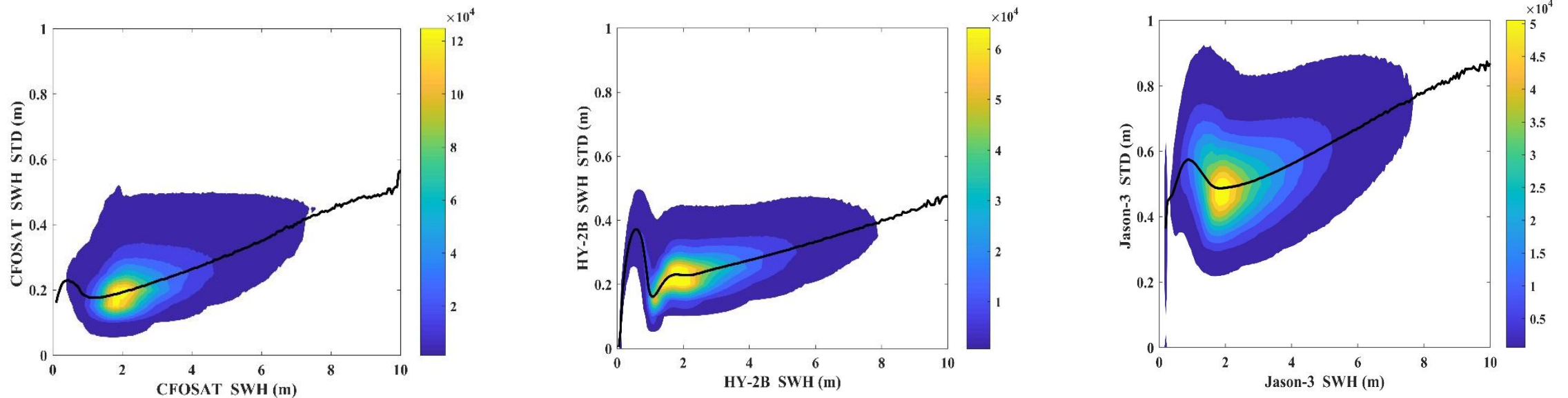

Density plots of precision for CFOSAT, HY-2B, and Jason 3 SWH STD dependency on SWH. Bin size is 0.05m×0.05m. Black line shows the median of each SWH bin.



# Collocation characteristics for CFOSAT and Jason-3 Nadir SWH

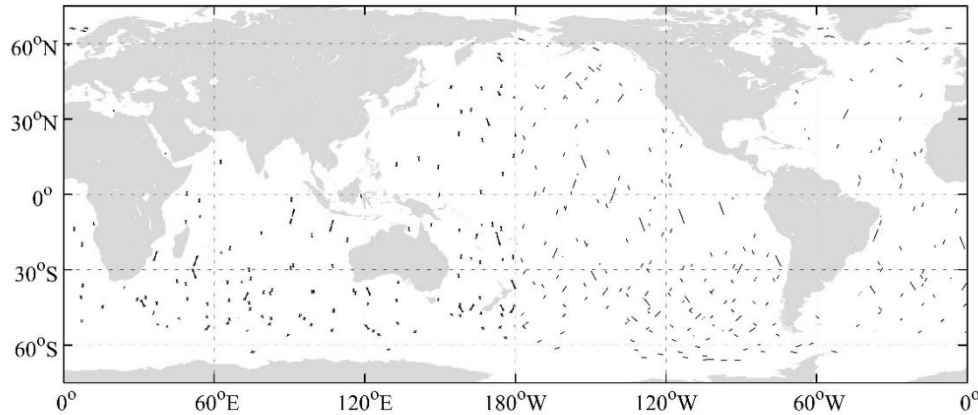

Prior to calibration, the “Bias,” “STD,” “root mean square error (RMSE)” and “scatter index(SI)” are 0.09, 0.21, 0.23 m, and 0.08, respectively

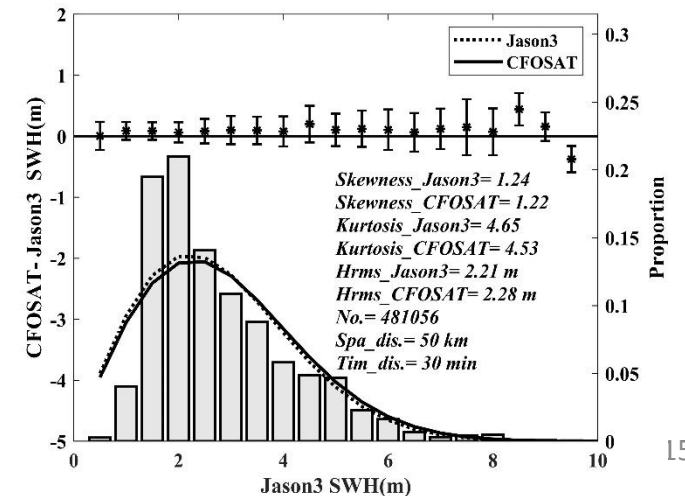
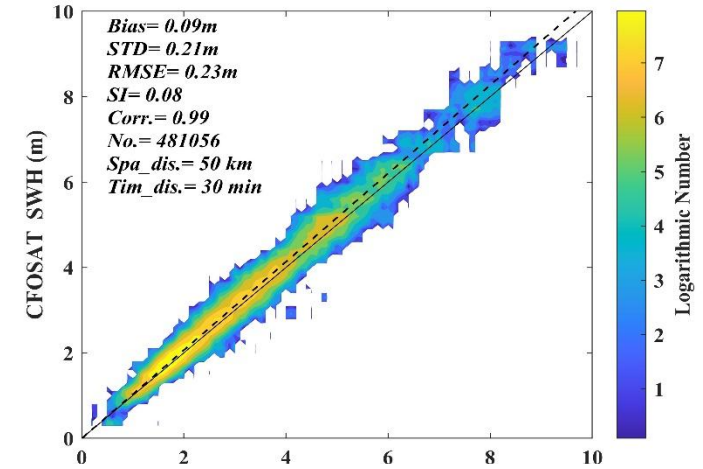



# Collocated CFOSAT Nadir and Buoys SWH

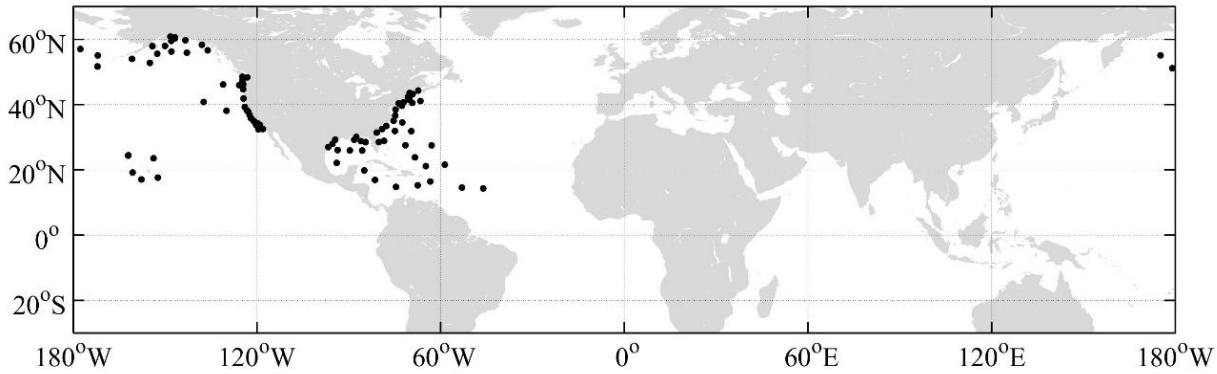

Values for “*STD*” and “*RMSE*” are 0.24 m and 0.27 m, respectively.

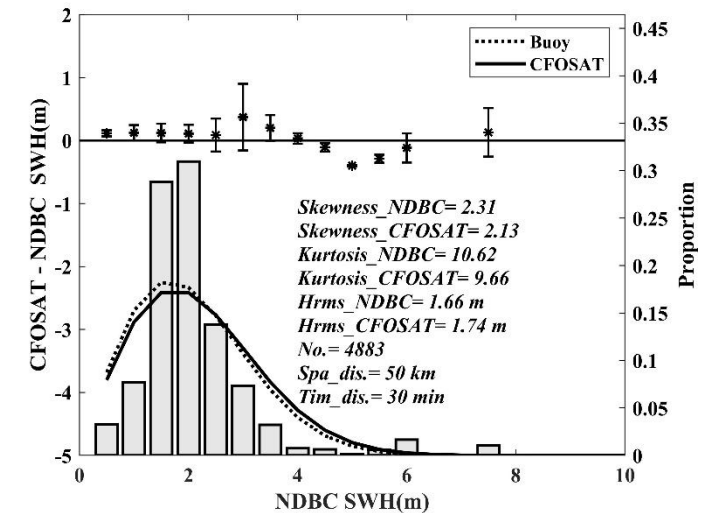
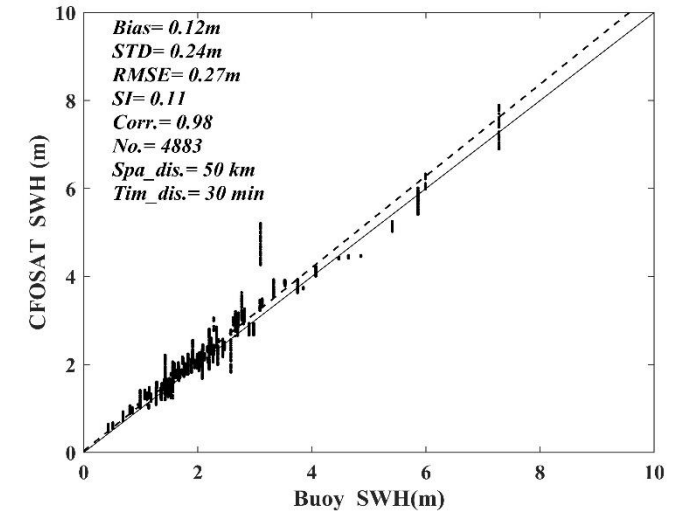





- CFOSAT met typhoon Lingling (2019) and measured wind and wave fields at about 10:22 UTC on September 4.

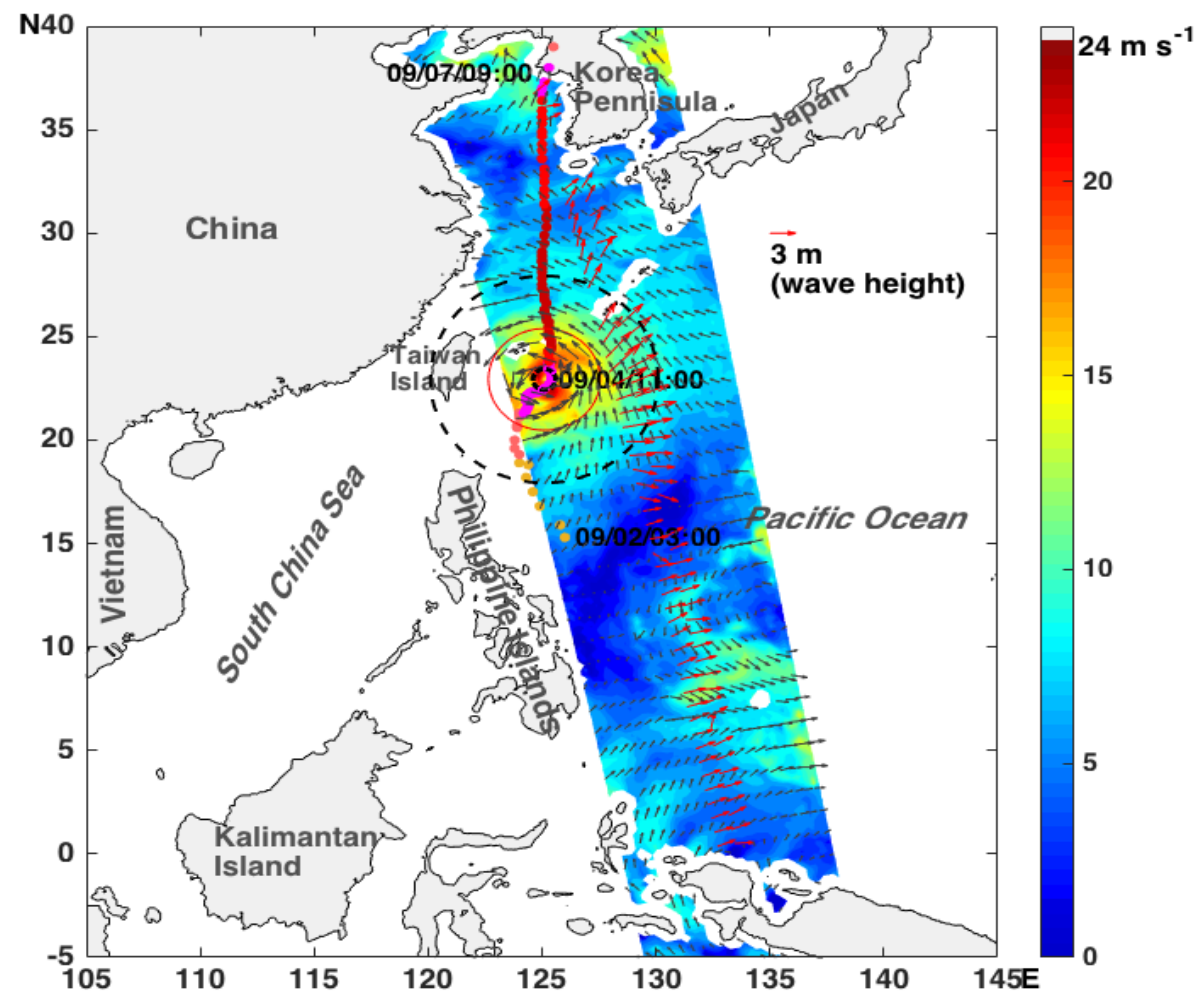



- Comparison of the CFOSAT wind vectors to the remote sensed surface winds from CMEMs two hours later at 12:00 UTC on September 4, 2019
- The mean difference of wind speed is 1.1 m/s

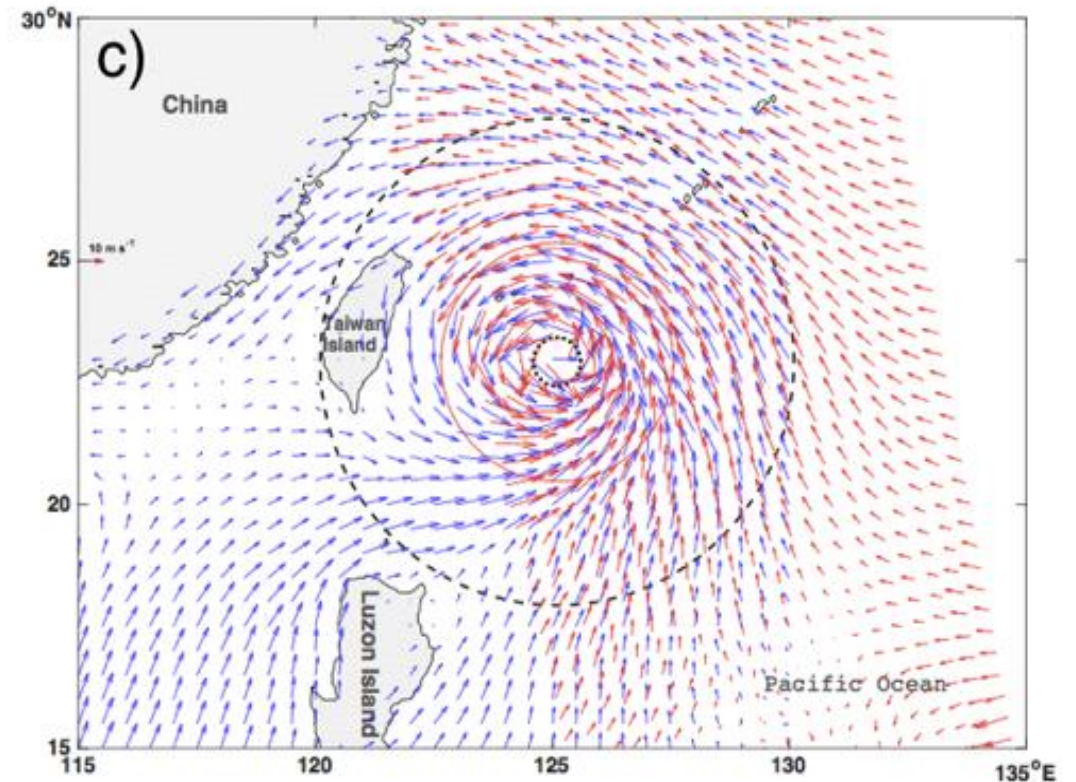

- The SWH and Dominant Wave length of SWIM observation during typhoon Lingling

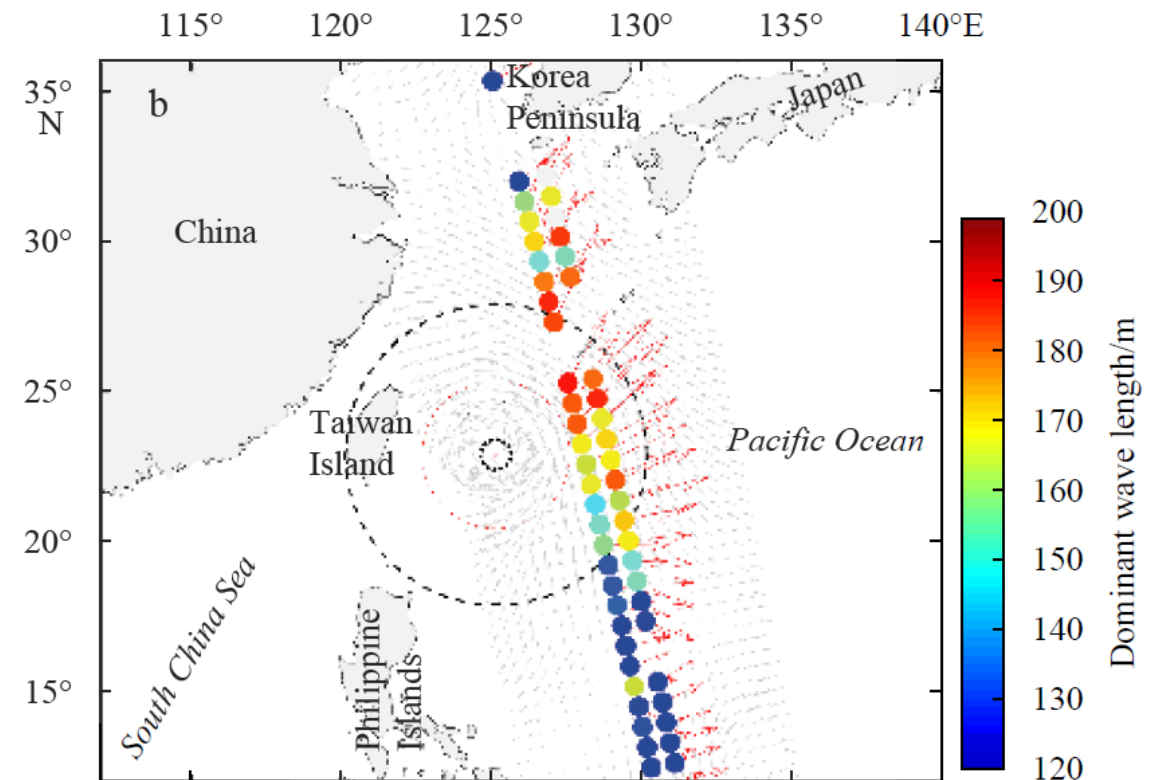
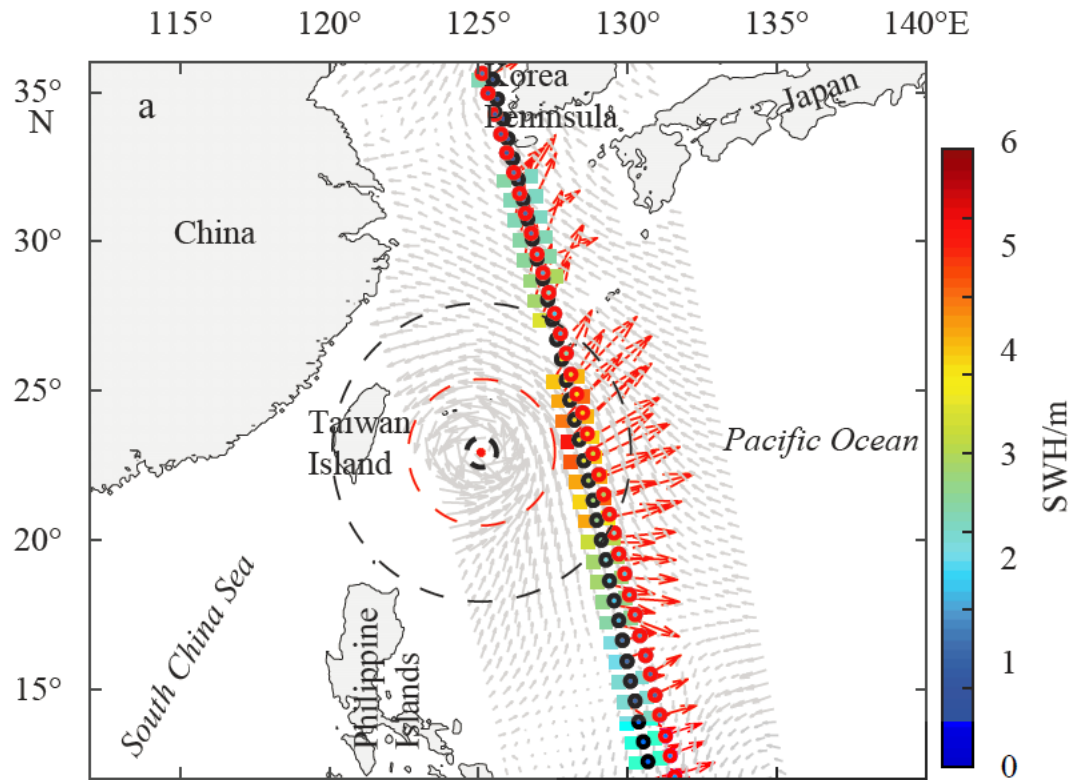



- Comparison of CFOSAT observed SWHs and estimated SWHs based on the P-M spectrum.

$$h_{PM} \approx 0.22 \frac{(U_{10})^2}{g}$$

Stewart (2008)

NOTE: SWIM product version 4.3.2

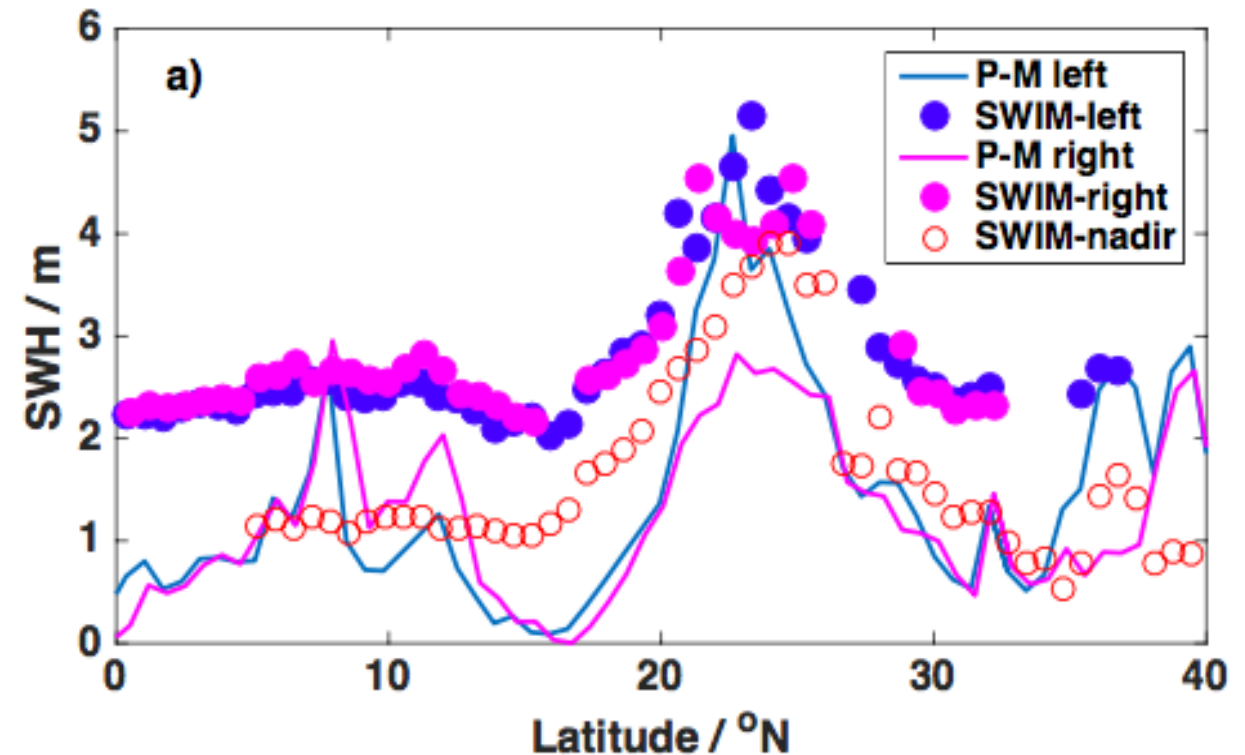

- Comparison of observed deviation angles and theoretical deviation angles.

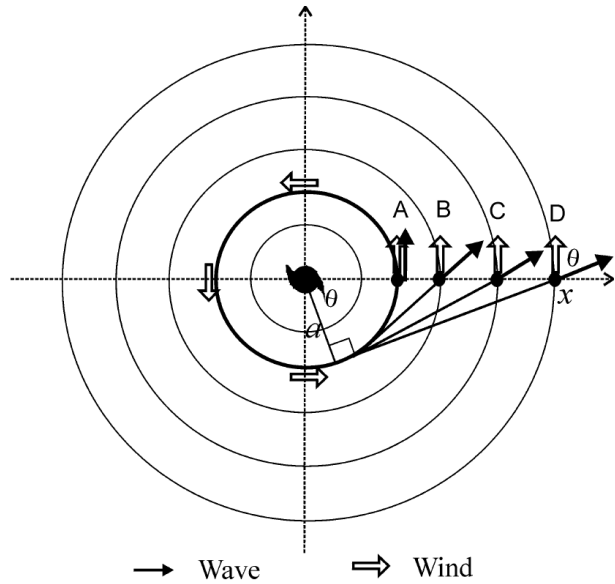

$$\theta = \cos^{-1}(a/x) \quad (x \geq a)$$

Moon et al. (2003)

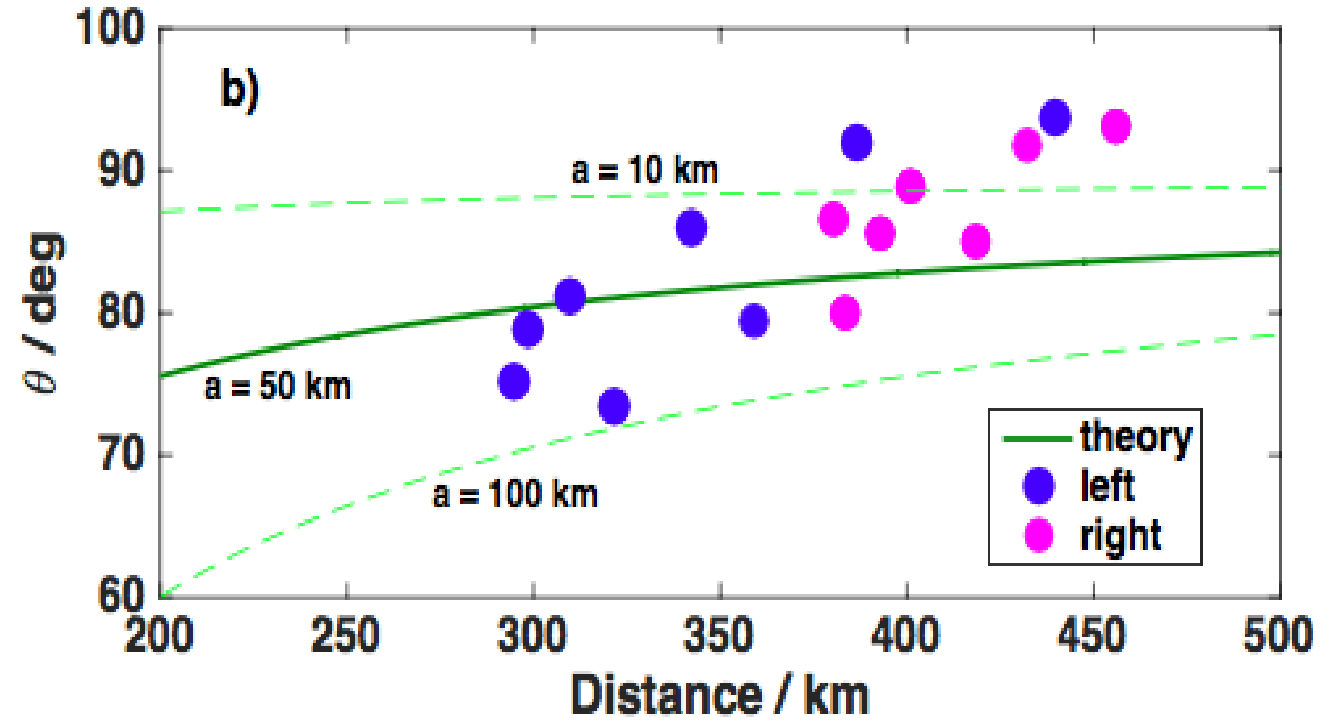



- Simultaneous CFOSAT observation of wind fields and wave fields under typhoon Lingling.

**CFOSAT simultaneous observation of super typhoon ‘Lingling’ in 2019**

**Cover story of *Acta Oceanologica Sinica* 2019 38(11)**

***By: Ying Xu, Jianqiang Liu, Lingling Xie\*, Congrong Sun, Jinpu Liu, et al.***

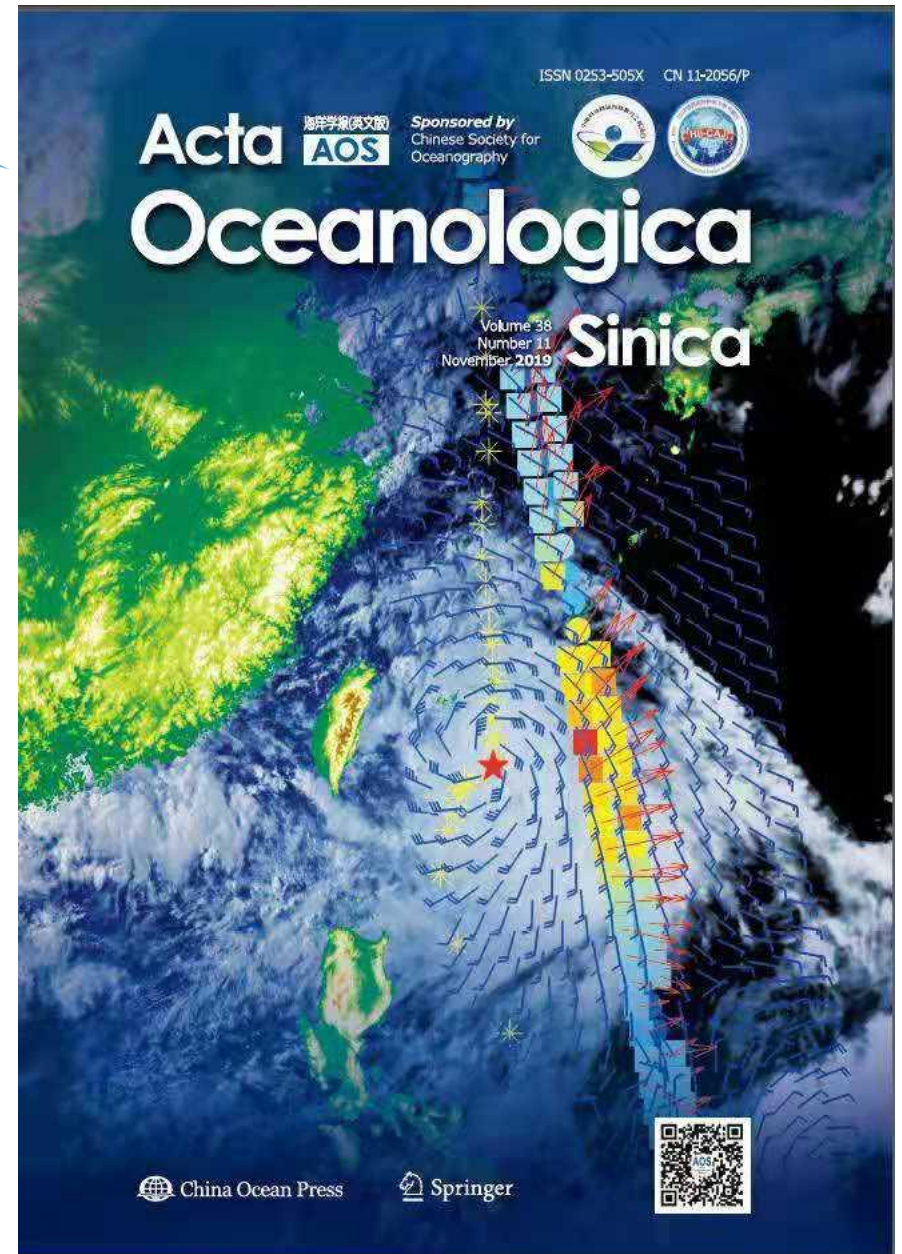

- Simultaneous CFOSAT observation of wind fields and wave fields under typhoon Maysak, 2020.

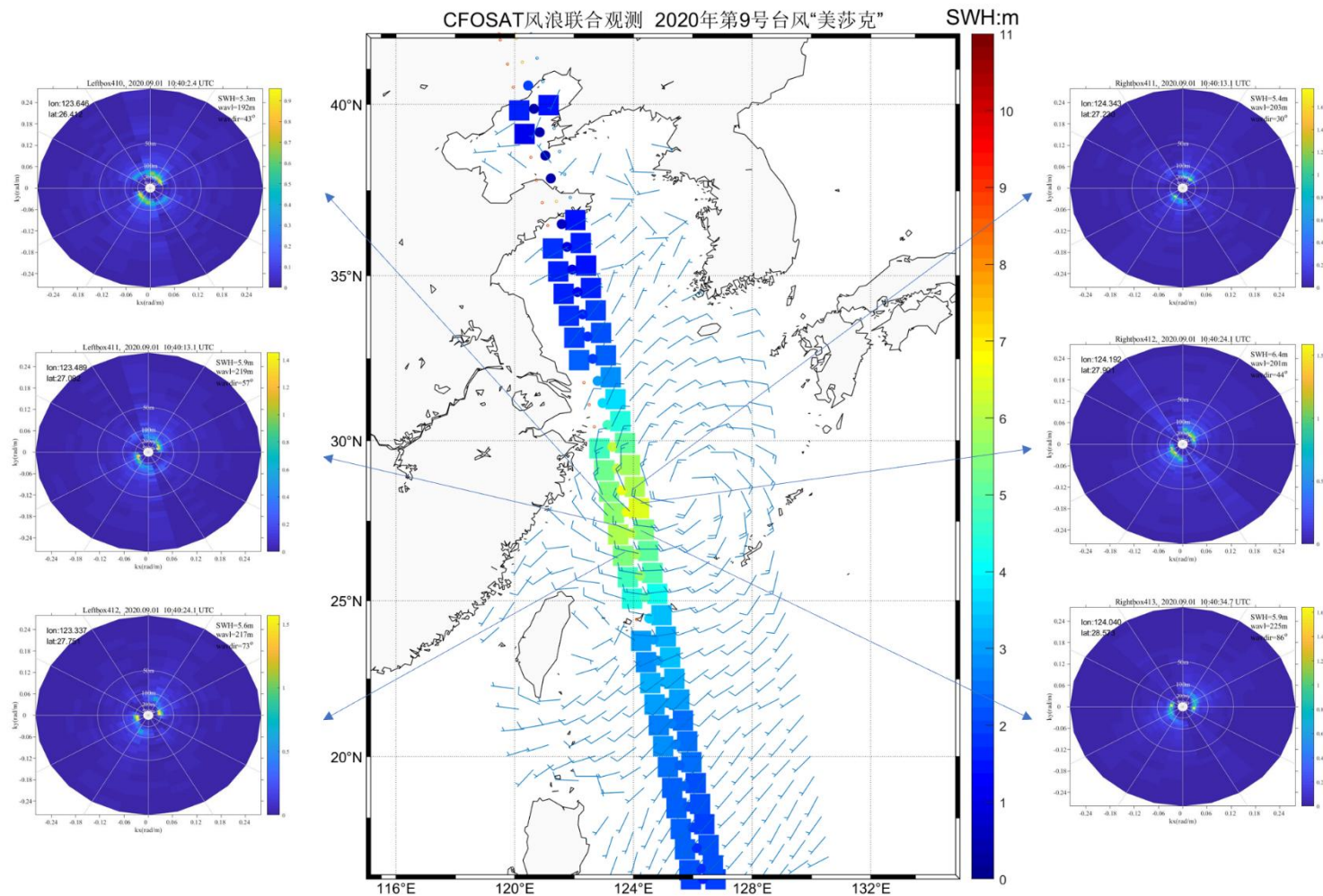



## Chinese GF-3 satellite

- GF-3 SAR has 12 imaging modes, e.g., Spotlight (SL), fine strip (FS), quad-polarization strip (QPS), and wave mode (WAV).
- On 5 December 2019, The footprints of CFOSAT passed the 6 GF-3 SAR images acquired in FS mode imaged at 10:48–10:53 UTC

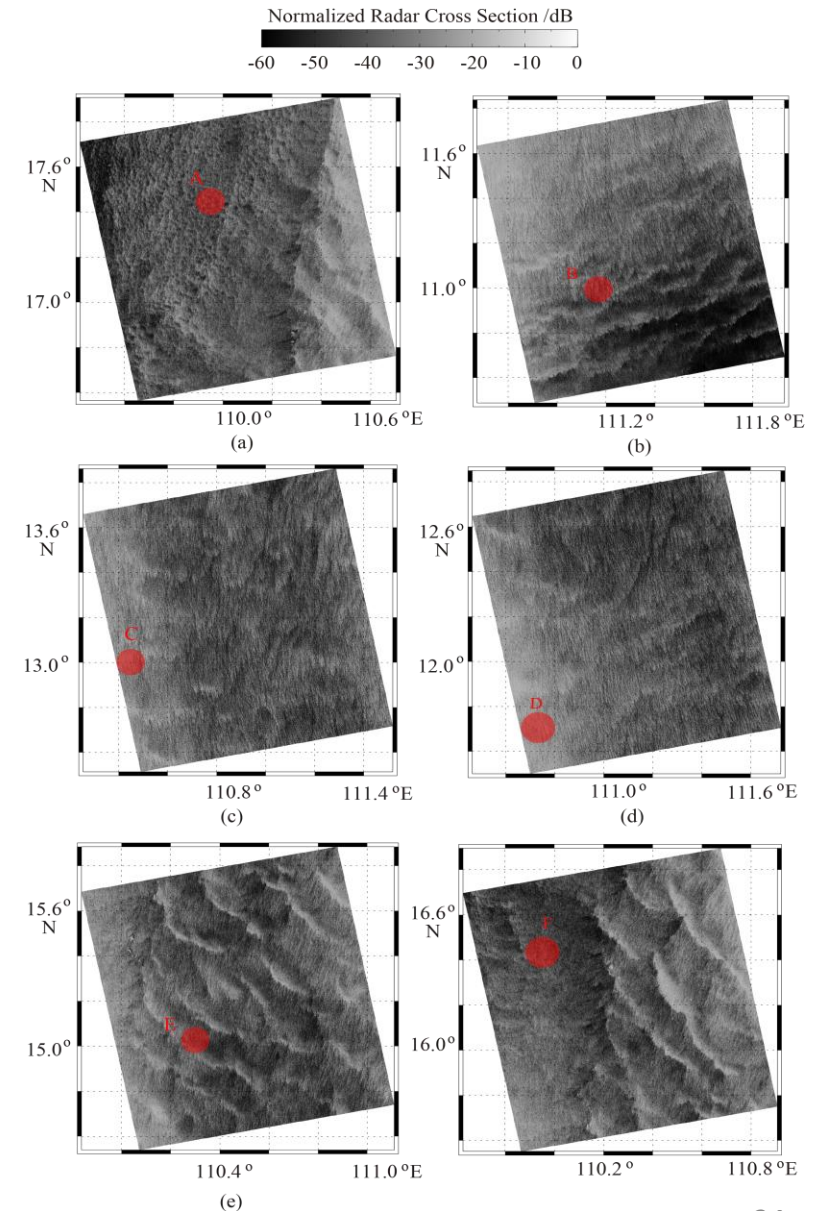



## One-dimensional CFOSAT-spectrum and the GF-3 SAR spectrum

- GF-3 SAR spectra were most consistent with the CFOSAT-spectra at incidence  $10^\circ$
- Short waves with wave numbers  $> 0.1$  rad/m were undetectable in the SAR spectra
- CFOSAT spectra, however, were up to  $0.25$  rad/m wave number.

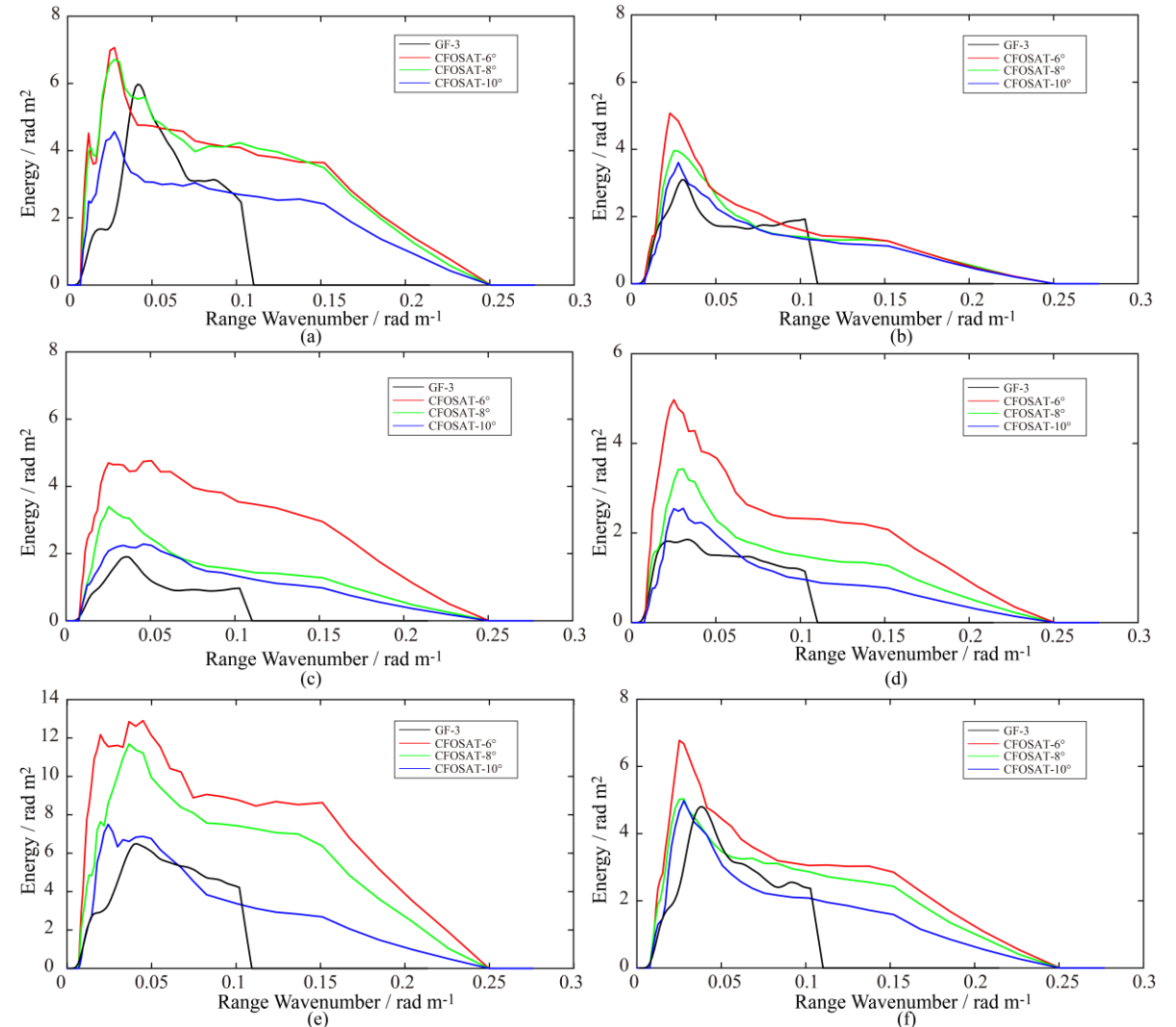

# On the First Observed Wave Induced Stress over the Global Ocean

Sheng Chen, Anna Rutgersson, Xunqiang Yin, Ying Xu, Fangli Qiao\*

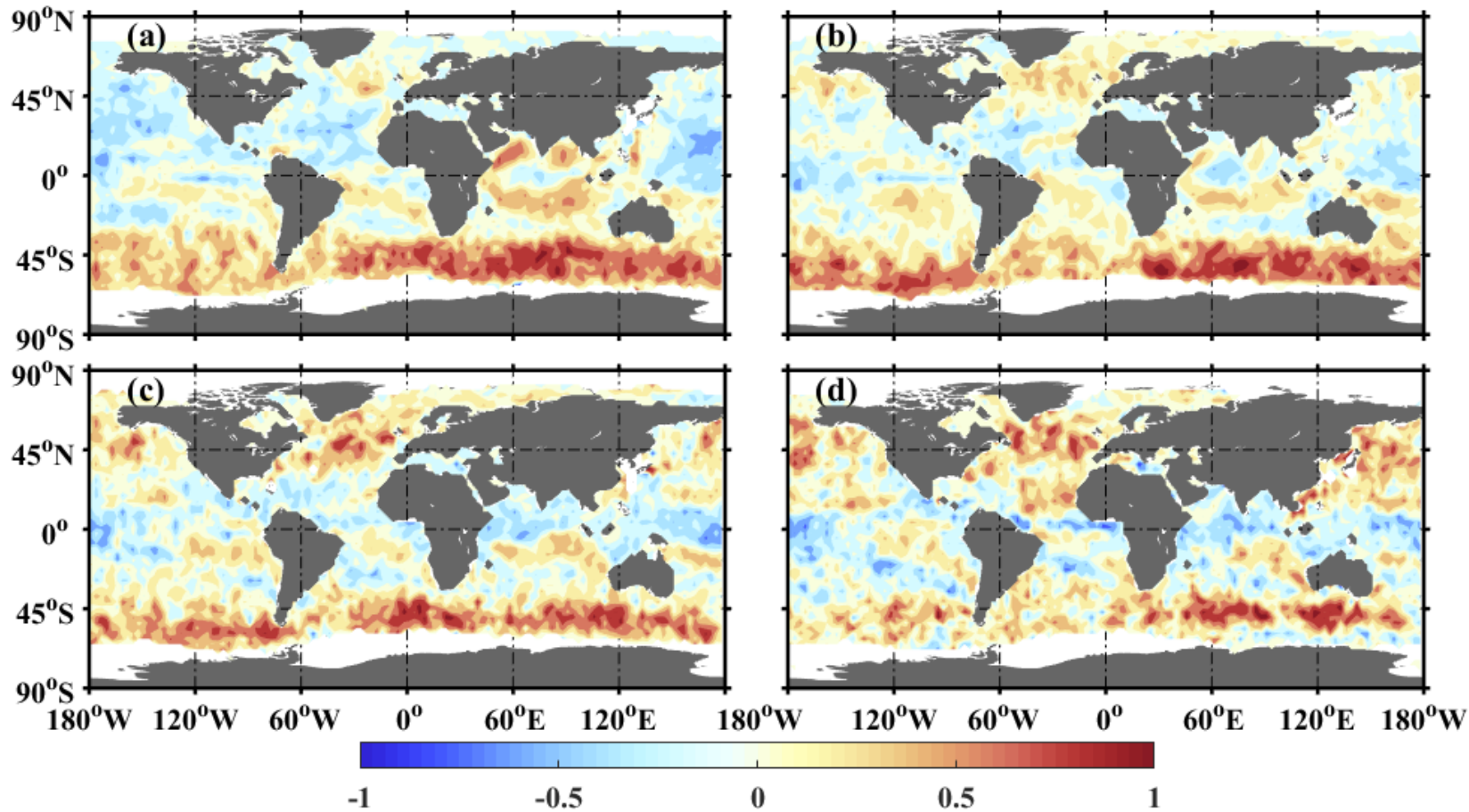

**Later summer**

- Indian Ocean monsoon zone
- Westerlies of the SH

$\tau_w < 0$

● Aug. to Nov.:

50% to 27% for NH

- Close to equator:  
~ 60%

# Directional and frequency spread of surface ocean waves from CFOSAT/SWIM satellite measurements

E. LE MERLE, D. HAUSER, C. PEUREUX, L. AOUF, P. SCHIPPERS, C. DUFOUR, A. DALPHINET

**Map of SWIM  $BFI_{2D}$  computed with beam  $10^\circ$  spectra  
from 2019-09-10 to 2019-09-22**

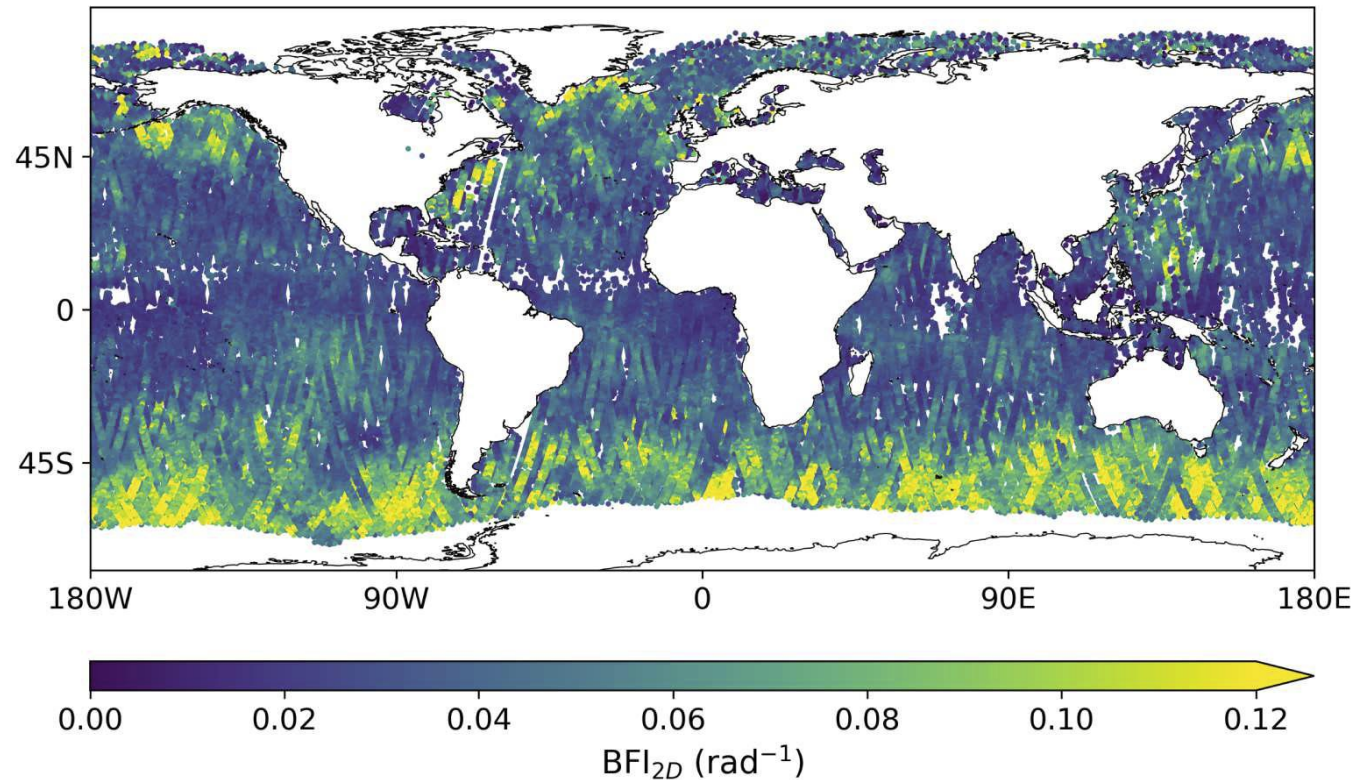

Directional Benjamin Feir Index  
( $BFI_{2D}$ )

First map of BFI at the global  
scale  
obtained exclusively with  
observations.

Appropriate indicator of non-linear  
interactions between waves and of  
probability of occurrence of  
extreme waves

# Asymmetric wave distributions of tropical cyclones based on CFOSAT observations

- Yanping SHI, Yan DU, Xiaoqing CHU, Shilin TANG, Ping SHI, Xingwei Jiang

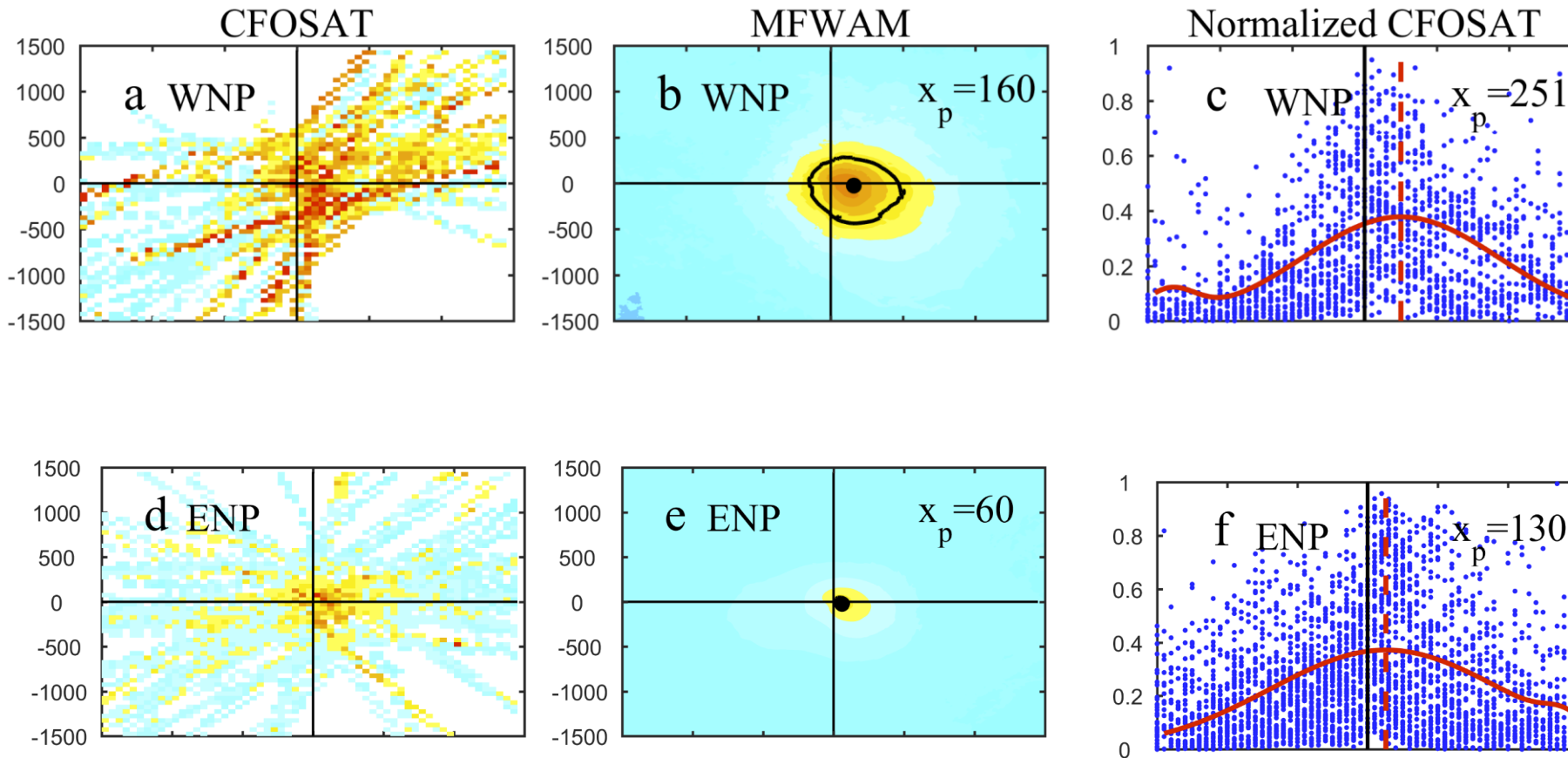

Positive value of the expectation reveals the peak SWH is on the right side about 251 km of the typhoon track.

Similarly, the high wave occurs around TCs center and the peak value of SWH appear on the right of TCs about 130 km away.

# On the assimilation of SWIM directional wave observations in wave model : A success story from CalVal phase to operational use

L. Aouf, A. Dalphinet, D. Hauser, B. Chapron , J. Wang,  
C. Toussin

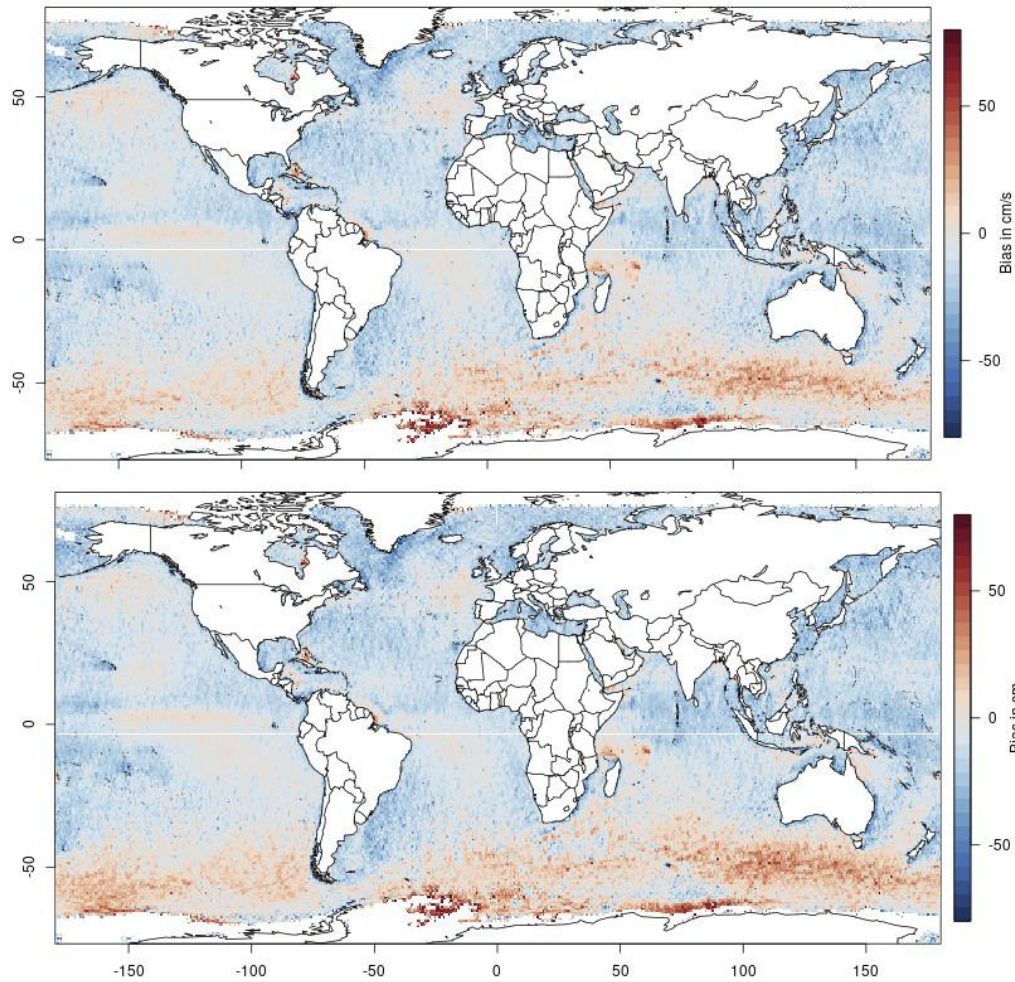

Since 2nd february 2021 the assimilation of partitions wavenumbers is activated in operational global model CMEMS and Meteo-France. wave product such SWH is significantly improved (SI of  $\sim 8\%$  in average)

Bias maps of SWH : July - December 2019  
Impact of the assimilation of SWIM-NRT (Kx-Ky)

# Effects of ocean eddies on surface wave features

Lingling Xie<sup>1\*</sup>, Keyi Tan<sup>1</sup>, Quanan Zheng<sup>2,1,3\*</sup>, Junyi Li<sup>1</sup>, Ying Xu<sup>3</sup>

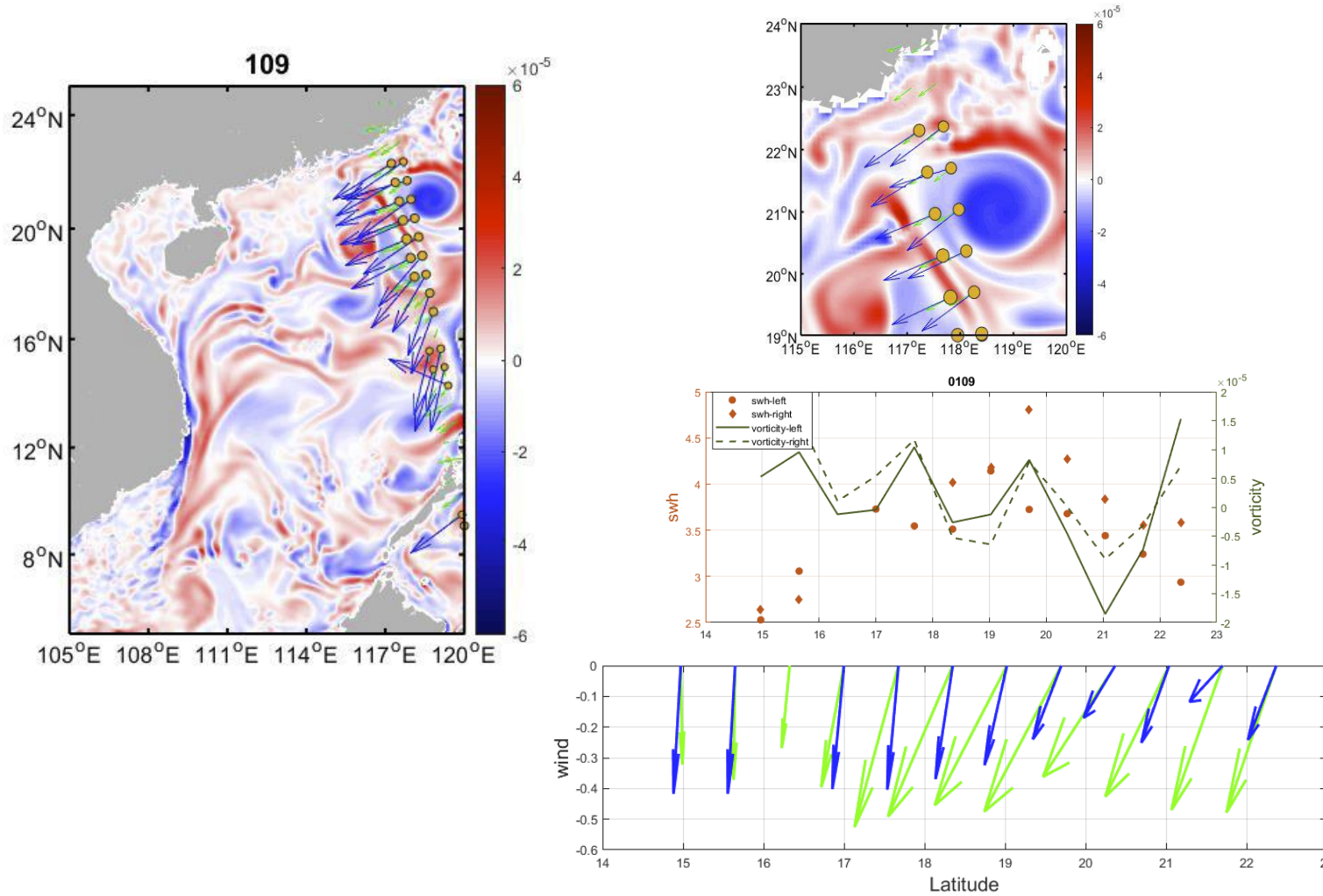

SWH at the inside the eddy are generally higher than that outside the eddy.

The wave propagation directions change significantly at the eddy edge where submesoscale frontal processes occur.

## **4 Validation and merging of HY-1 and multiple satellite data**

## **Application objectives and configuration of HY-1**

**Operational monitoring of ocean color environment, continuous get global ocean color and sea surface temperature data, environmental change data of the China Sea and its coastal zone;**

**To study and master the distribution of Marine primary productivity;**

**Study the meso-scale of Marine environmental change;**

**Monitoring environmental changes in China's coastal zone.**



# **Application objectives and configuration of HY-1**

**It focuses on the monitoring and forecasting of ocean color environment, red tide, green tide, pollution, fishing grounds, sea ice and sea surface temperature.**

**Service in natural resources survey, environmental ecology, emergency disaster reduction, meteorology, agriculture, water conservancy and other industries.**

**Adoption of morning and afternoon networking to increase the number of observations and improve the global coverage capacity;**

**Equip with ocean color and temperature scanner, coastal zone imager, ultraviolet imager, onboard calibration spectrometer, ship automatic identification system.**

# Technical specific of HY-1

Five payloads (COCTS, CZI, UVI,SCS,AIS)

**COCTS:** ocean color and sea surface temperature scanner, global operation, spatial resolution of 1000 meters, width of more than 2900 kilometers, 10 channels, SNR is better than 400, daily access to global ocean chlorophyll concentration, suspended sediment, soluble organic matter, sea surface temperature and green tide, sea ice, Arctic and Antarctic sea ice information, the production of scale 1:100 million to 4 million topical map;

**CZI:** Coastal zone imager, with a signal-to-noise ratio of more than 250, spatial resolution of more than 50 meters, a width of 1,000 kilometers, 4 channels, no lateral swing can be achieved once every three days coverage, high frequency, fast timeout, time series images can show the seasonal changes of vegetation and the process of water changes in rivers, rivers, lakes and seas. Can make scale 1:50 to 200,000 thematic map



# Satellite characteristic



Item	HY-1A	HY-1B	HY-1C/D
Launch lime	2002.5.15 09:50AM	2007.4.11 11:27AM	2018.9.7 2020.6.11 11:15AM 02
Equator crossing time	8:53-10:10am (descending node)	10:30AM (descending)	10:30AM 13:30AM (descending/scending)
platform	CAST968	CAST968	CAST2000
Mass	367kg	422.5kg	816kg
launch vehicle	CZ-4B /pigback	CZ-2C	CZ-2C
Orbit type	Near Circular and near sun-synchronous		
Period	100.8 minute	100.8 minute	100.34 minute
Inclination	98.8 deg	98.8 deg	98.5 deg
Altitude	870→798km	798km	782 km
Attitude control	3 axis stabilized	3 axis stabilized	3 axis stabilized Satellite tilt (0, 20, -20)

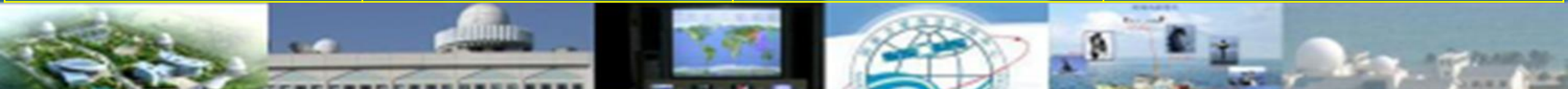



# Satellite characteristic



Item	HY-1A	HY-1B	HY-1C/1D
<b>Payload</b>	COCTS and CZI	COCTS and CZI	COCTS and CZI UVI SCS AIS
<b>Repeat period</b>	3days for COCTS, 7days for CZI	1days for COCTS 7days for CZI	1days for COCTS 3days for CZI
<b>Memory onboard</b>	80MB	250MB	512Gb
<b>Downlink</b>	X-band		
<b>Date rate</b>	5.3232Mbps	6.654Mbps	190Mbps
<b>TT&amp;C link</b>	S-band		
<b>Manufacturer</b>	CAST		
<b>Designed life</b>	2 years	3 years	5 years
<b>Work mode</b>	2 pass in china, 23 minutes each pass,1 pass ( 17 minute) outside china / COCTS	3 pass in china , 23 minutes each pass,4-5 pass (34 minute) outside china/cocts Or 2 pass outside china /czi	OCT AIS 24 hour work CZI 39 min outside china



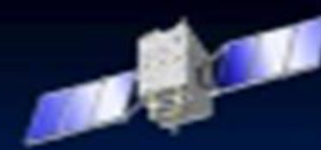

## Major parameters of COCTS

Parameter	HY-1A	HY-1B	HY-1C/1D
Spatial resolution	1.1km	1.1km	1.1km
Scan coverage	1400km	3000km	2900km
Digitization	10bit/pixel	10bit/pixel	12 bit/pixel
Radiometer accuracy	10%	10%	10%





# COCTS bands and detecting object

Band ( micro m )	Main detecting object
0.402-0.422	Yellow substance、 water pollution
0.433-0.453	Chlorophyll absorption
0.480-0.500	Chlorophyll、 sea ice、 pollutant
0.510-0.530	Chlorophyll、 water depth、 pollutant、 suspended sediment
0.555-0.575	Chlorophyll、 vegetation、 sand
0.660-0.680	Fluorescence、 suspended sediment、 atmospheric correction、 aerosol
0.730-0.770	Suspended sediment、 atmospheric correction、 vegetation
0.845-0.885	Atmospheric correction、 water vapor
10.30-11.40	Sea Surface temperature
11.40-12.50	Sea Surface temperature



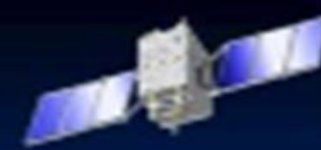

## Major parameters of CZI

Parameter	HY-1A	HY-1B	HY-1C/1D
Spatial resolution	250m	250m	50m
Scan coverage	500km	500km	1000km
Digitization	12bit/pixel	12bit/pixel	12 bit/pixel
Radiometer accuracy	10%	10%	10%





## *CZI bands and detecting object*

<i>Band ( micro m )</i>	<i>Main detecting object</i>
<i>0.42-0.50</i>	<i>Suspended sediment , pollutant , vegetation , sea ice</i>
<i>0.52-0.60</i>	<i>Pollutant , vegetation , ocean color , sea ice</i>
<i>0.61-0.69</i>	<i>Soil , Atmospheric correction , water vapor</i>
<i>0.76-0.89</i>	<i>Soil , Atmospheric correction , water vapor</i>





## 5 Monitoring of marine dynamics and marine environment disasters with multiple satellite



Marine satellite remote sensing  
reality applet

Get through the last mile of the  
service user

海洋卫星遥感实况小程序  
打通服务用户最后一公里

# Monitoring of Typhoon Dujuan with multiple satellites

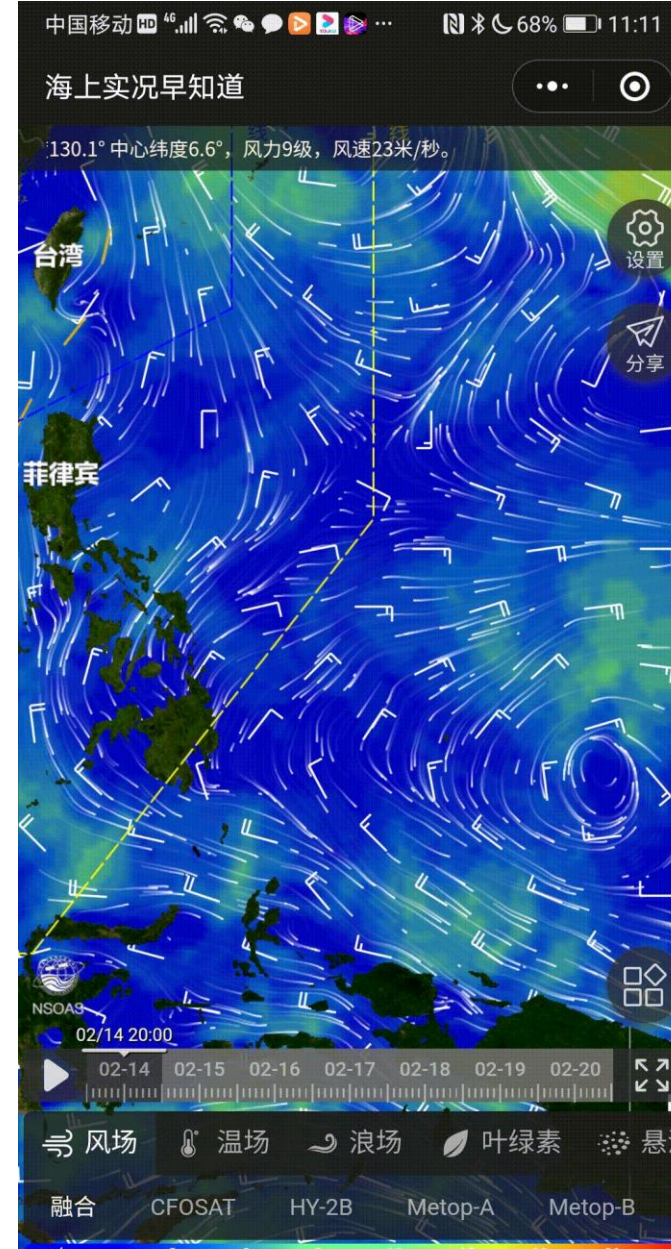
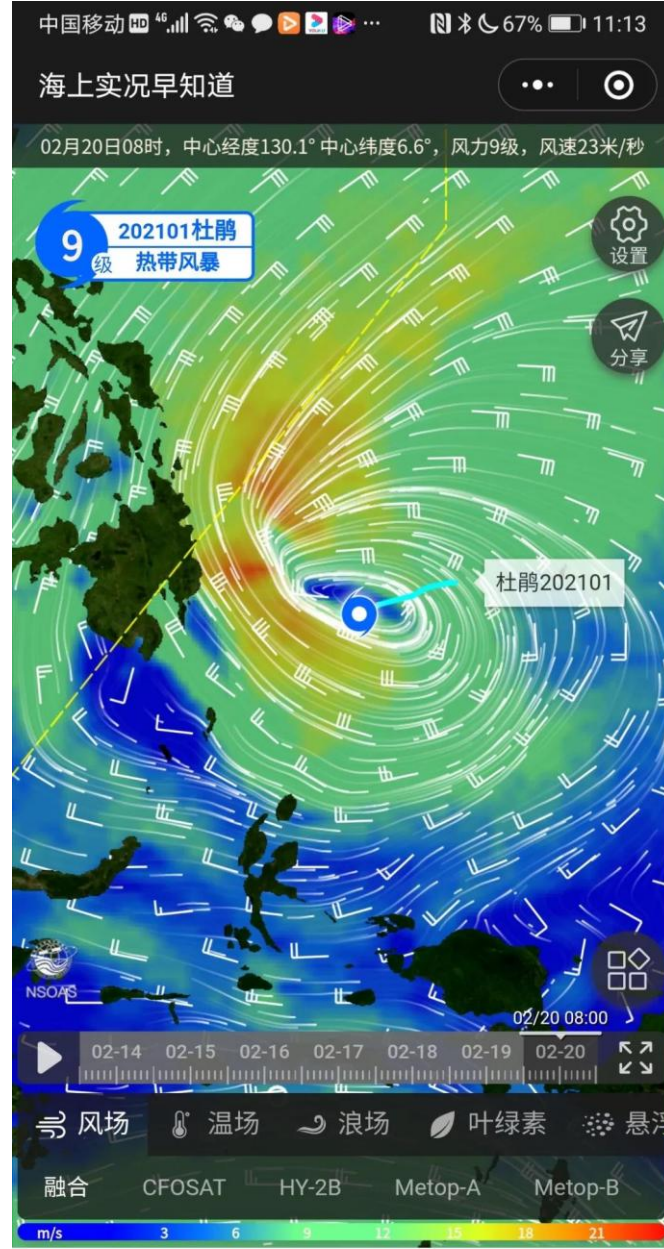

小程序



海洋卫星遥感实况

通过海洋卫星监测数据为公众、涉海企业及政府部门，提供及时有效的海上实况、实时...

国家卫星海洋应用中心

使用过

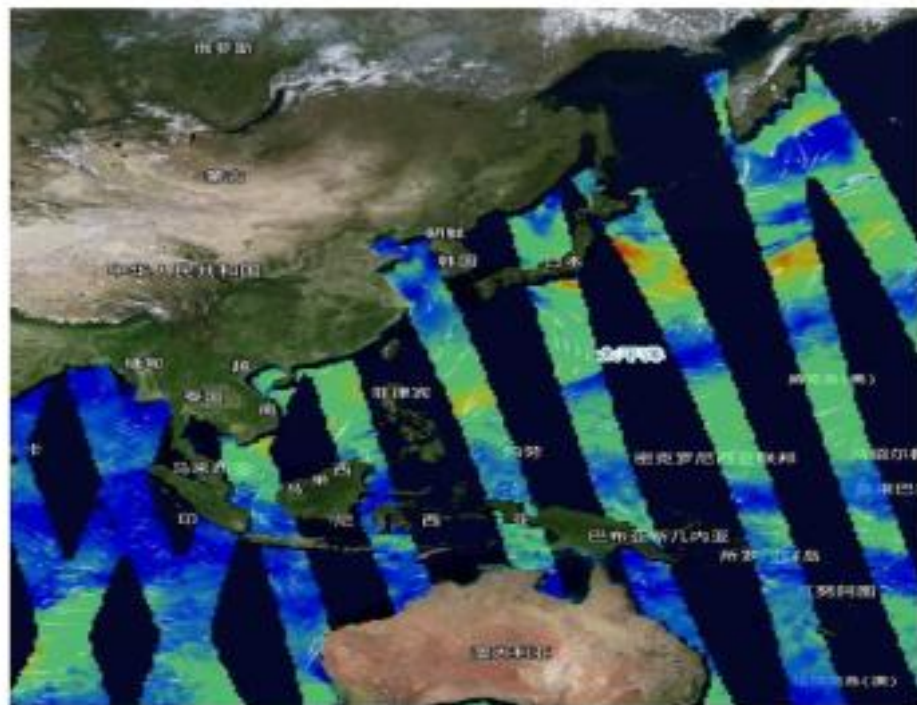
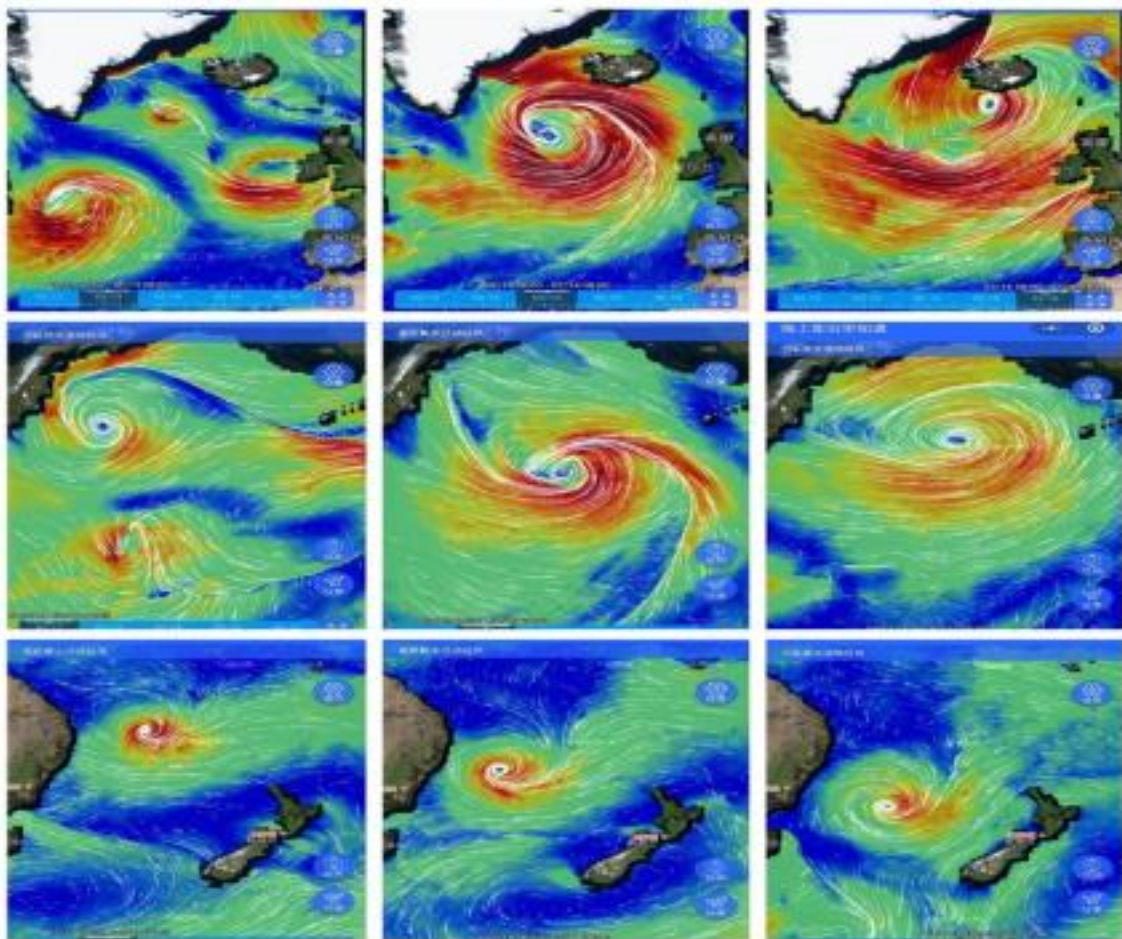

海洋卫星  
遥感实况

长按识别二维码  
国家卫星海洋应用中心

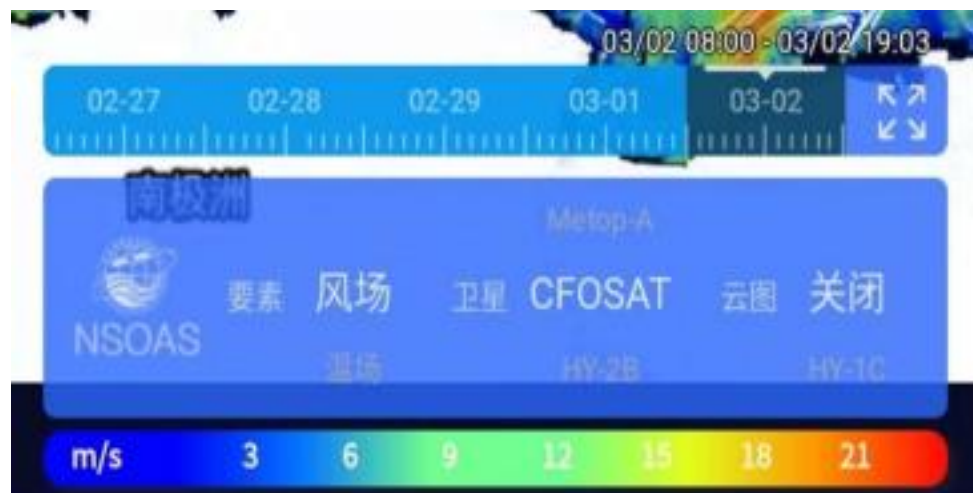

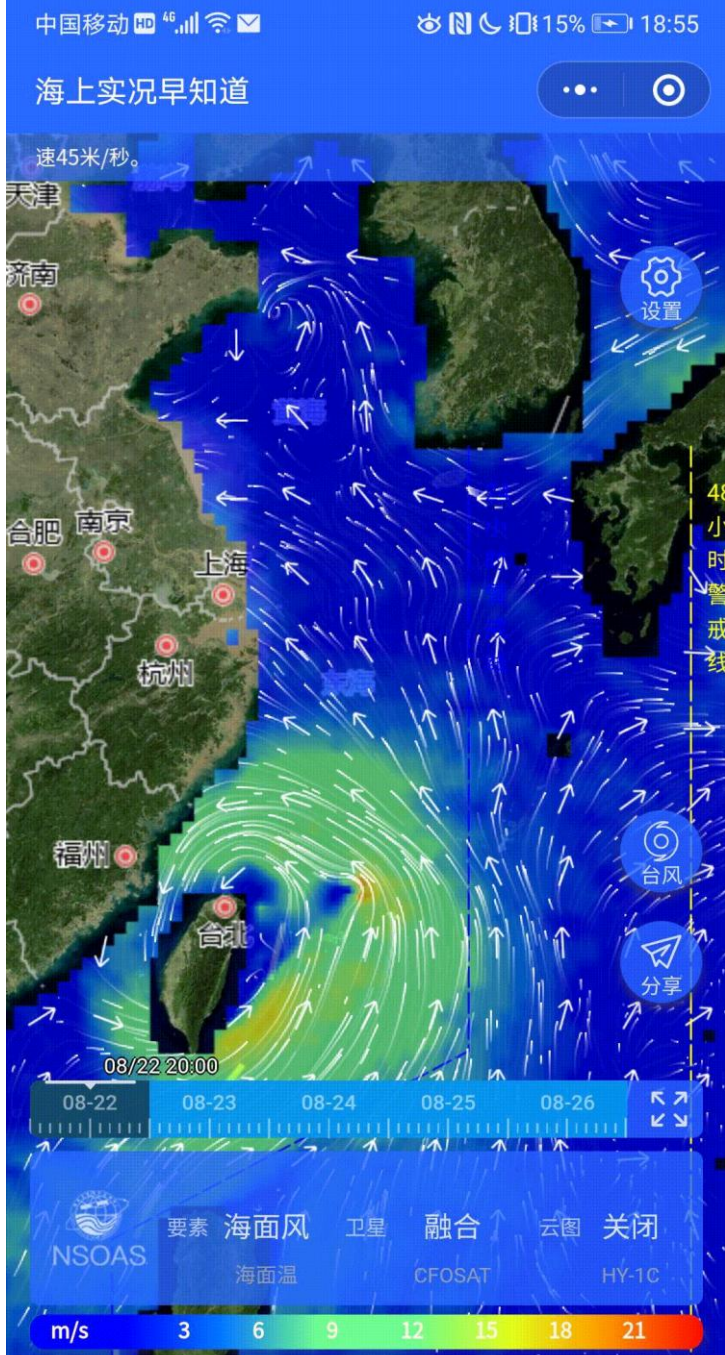

巴威

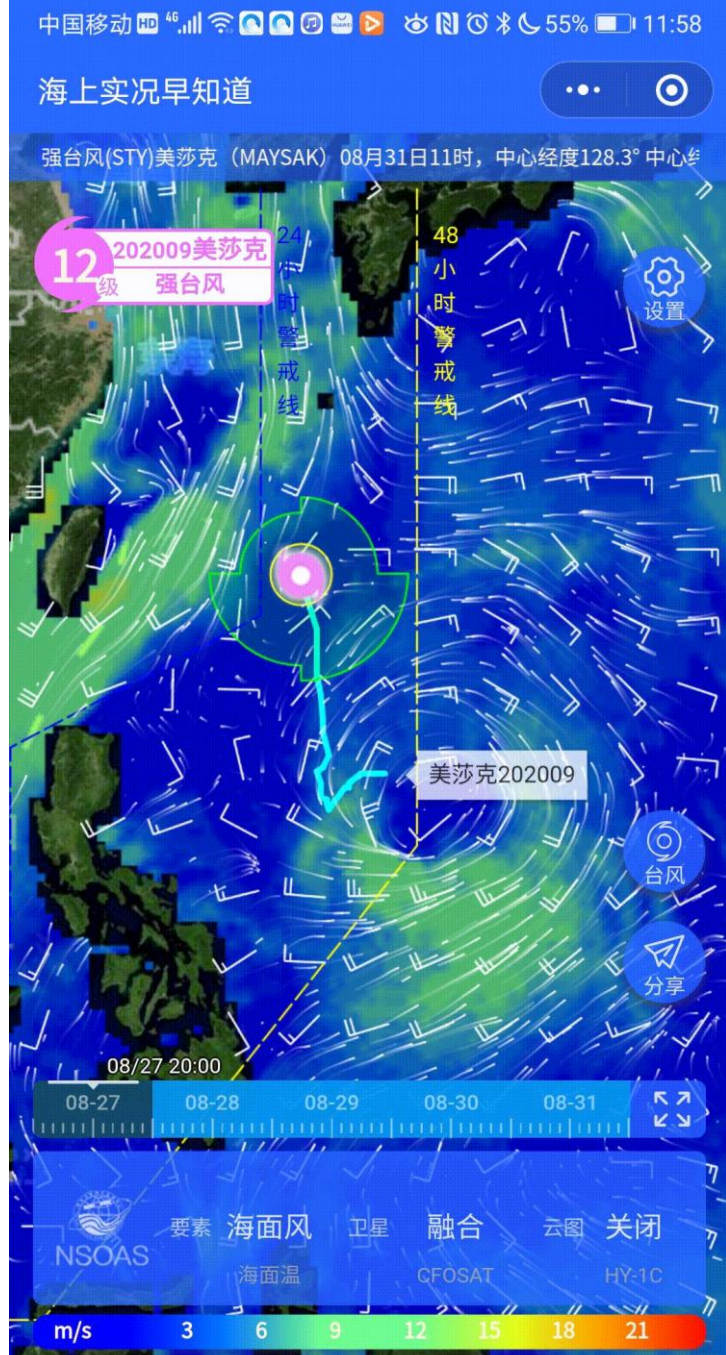

美莎克

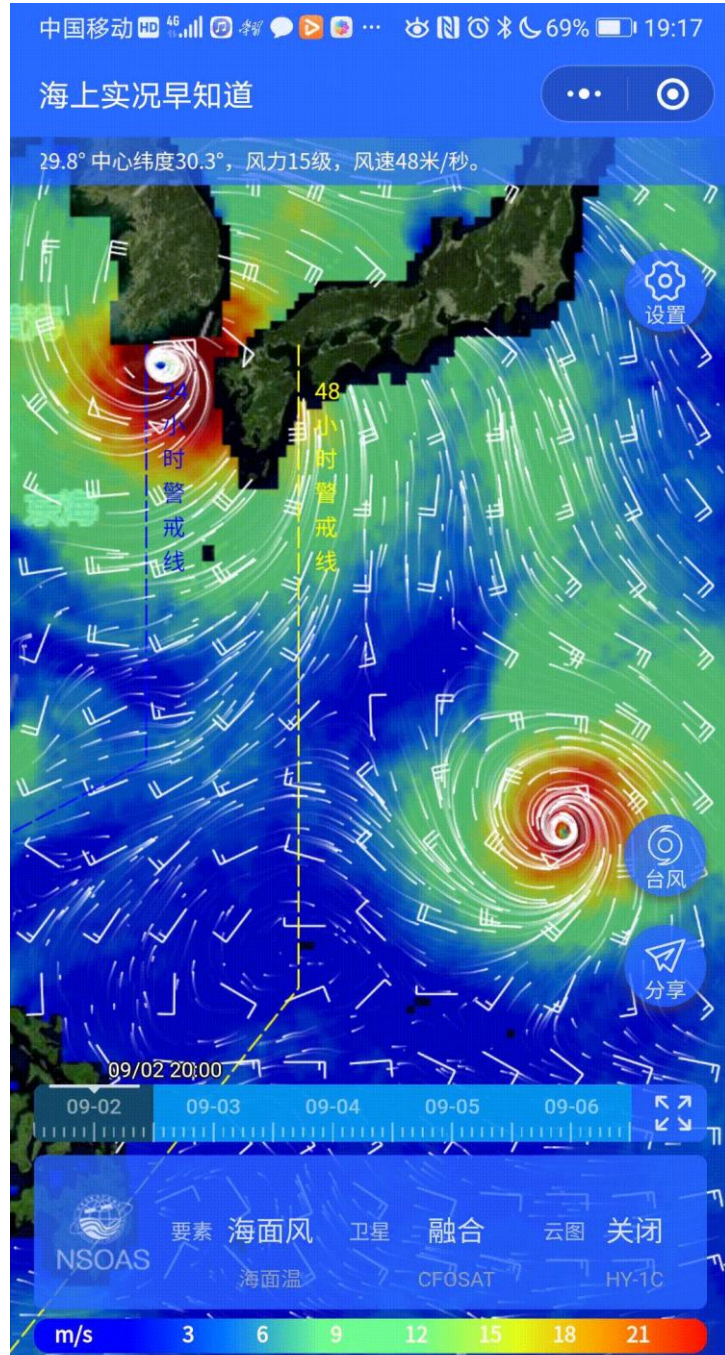

海神

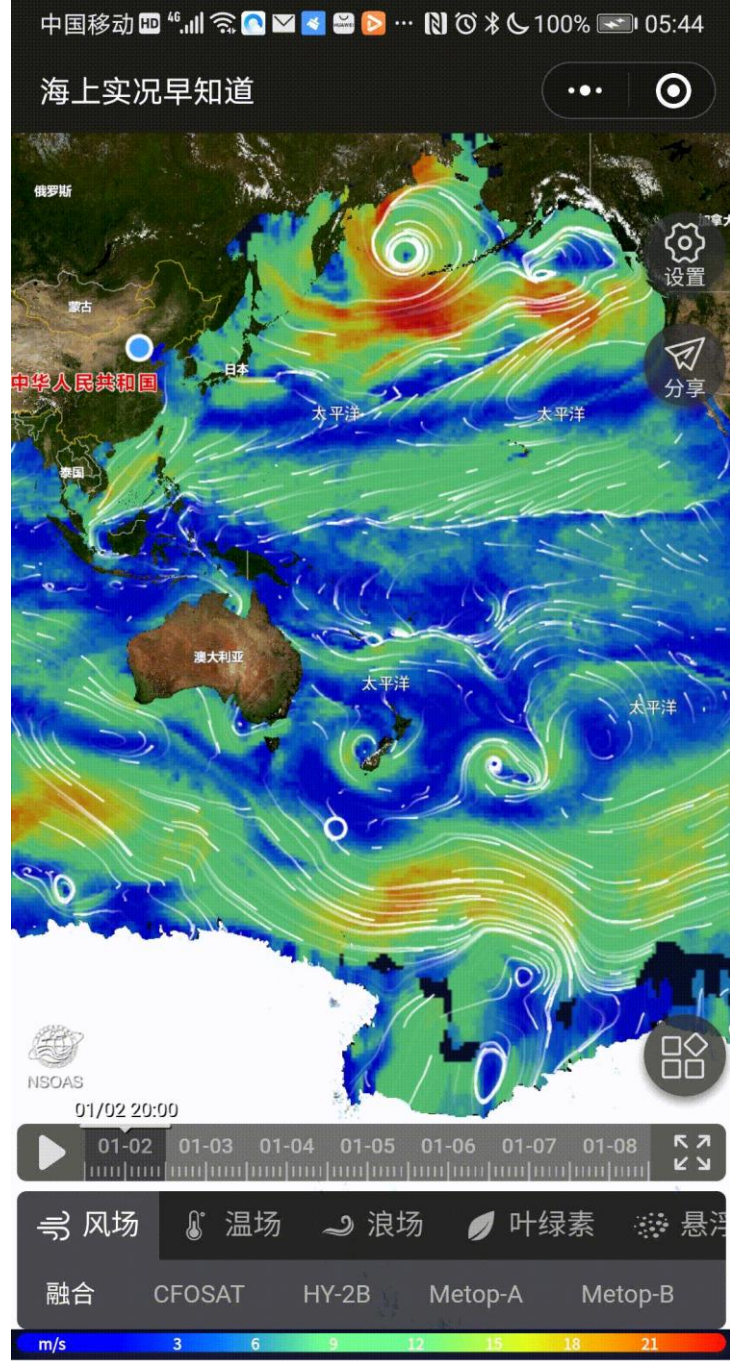
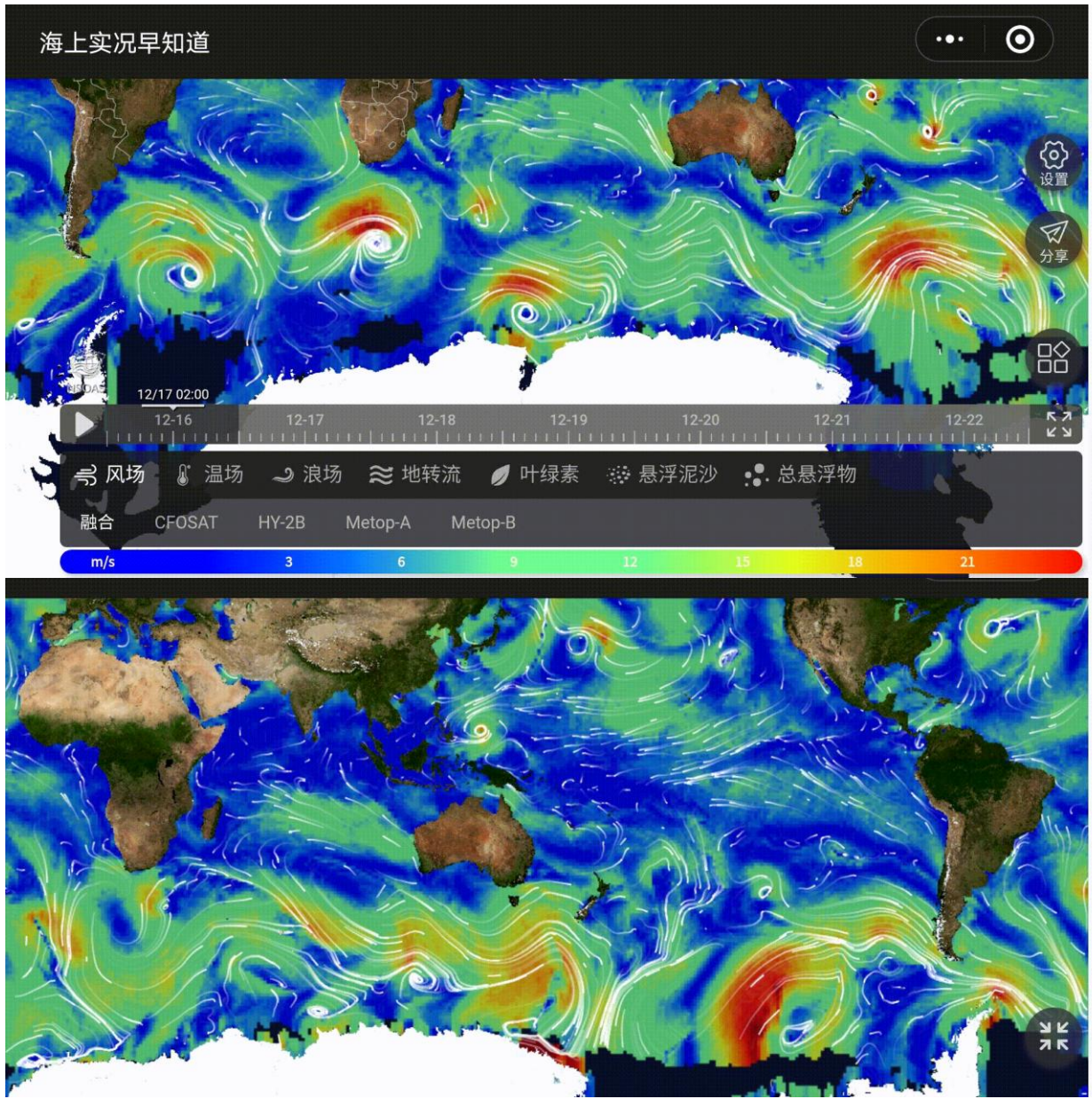

海洋卫星-极地遥感监测

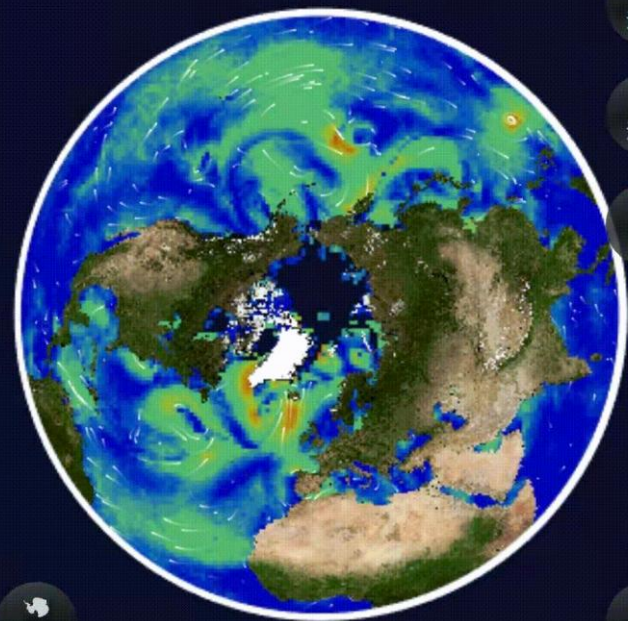

- 海冰
- 海风
- 海温
- czi

- 南极
- 更多
- 北极
- 分享

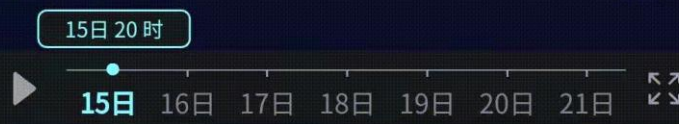

- 极地监测
- 重点区域
- 雪龙号

海上实况早知道

124.8° 中心纬度18.4°, 风力15级, 风速50米/秒。

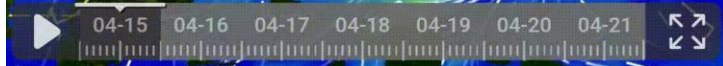
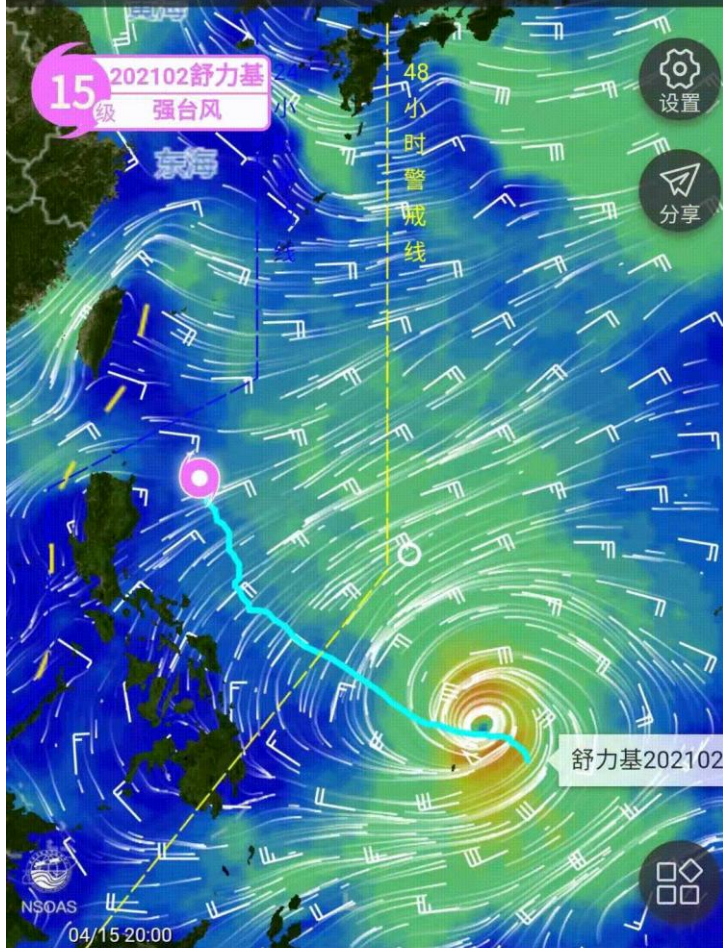

- 风场
- 温场
- 浪场
- 叶绿素
- 悬浮
- 融合
- CFOSAT
- HY-2B
- Metop-A
- Metop-B

海洋卫星-极地遥感监测

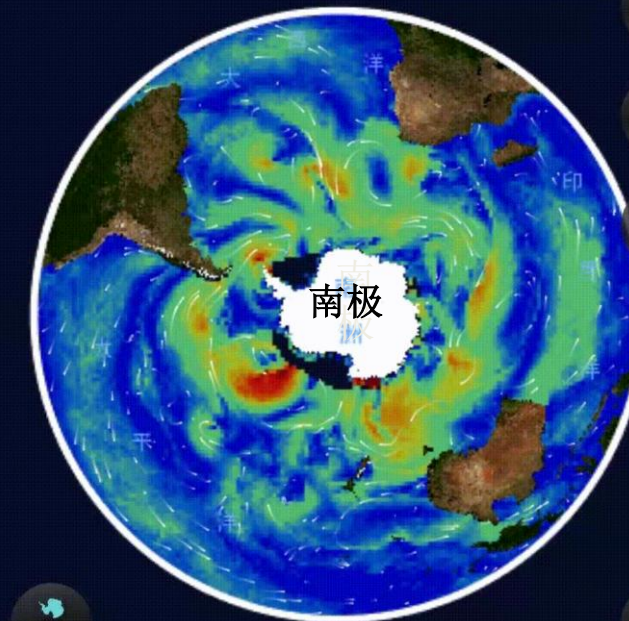

- 海冰
- 海风
- 海温
- czi

- 南极
- 更多
- 北极
- 分享

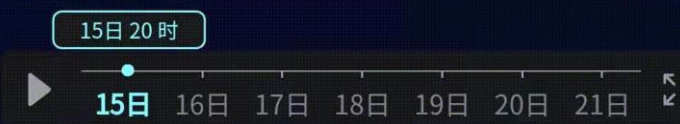

- 极地监测
- 重点区域
- 雪龙号

# Sea Ice monitoring

海洋一号D卫星黄渤海海冰遥感影像图



载荷: CZ1/海岸带成像仪 成像时间: 2021.01.17 0 20 40 80 千米 自然资源部国家卫星海洋应用中心

光学卫星遥感渤海及黄海海冰专题图

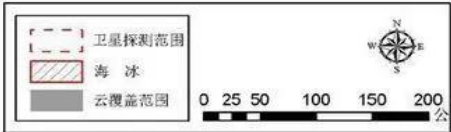

卫星/传感器: HY-1C COCTS、TERRA MODIS  
坐标系: CGCS2000  
成像时间: 2021年1月17日10时10分  
探测范围内海冰面积: 17447平方公里  
制作单位: 国家卫星海洋应用中心

Sea Ice monitoring with HY 1C/1D in Bohai

# 海洋一号C卫星辽东湾海冰遥感影像图

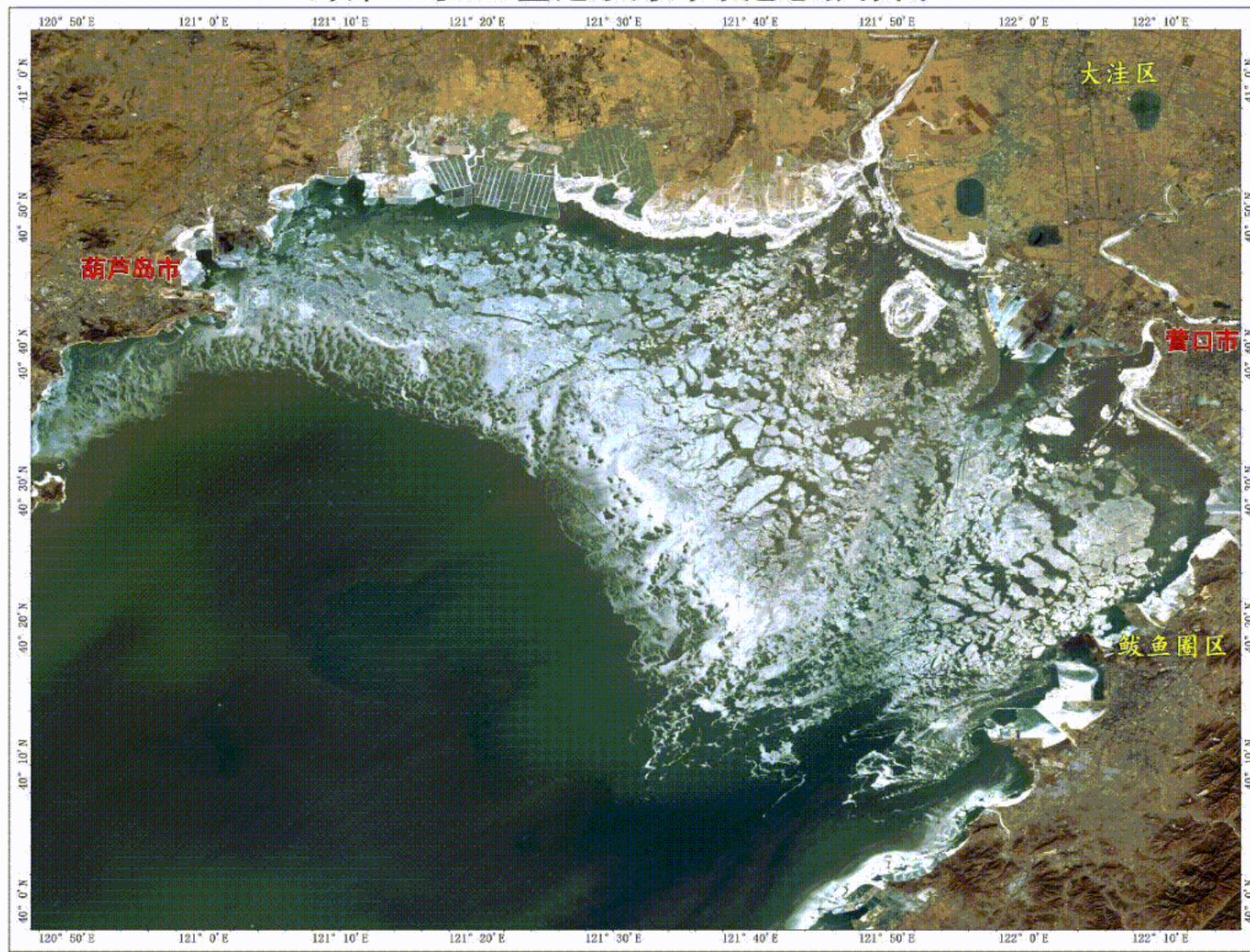

载荷: CZI/海岸带成像仪

成像时间: 2021.01.01

0 4 8 16 千米

自然资源部国家卫星海洋应用中心

Sea Ice monitoring with HY 1C/1D in Bohai



# Green Tide monitoring

卫星遥感绿潮监测信息合成图

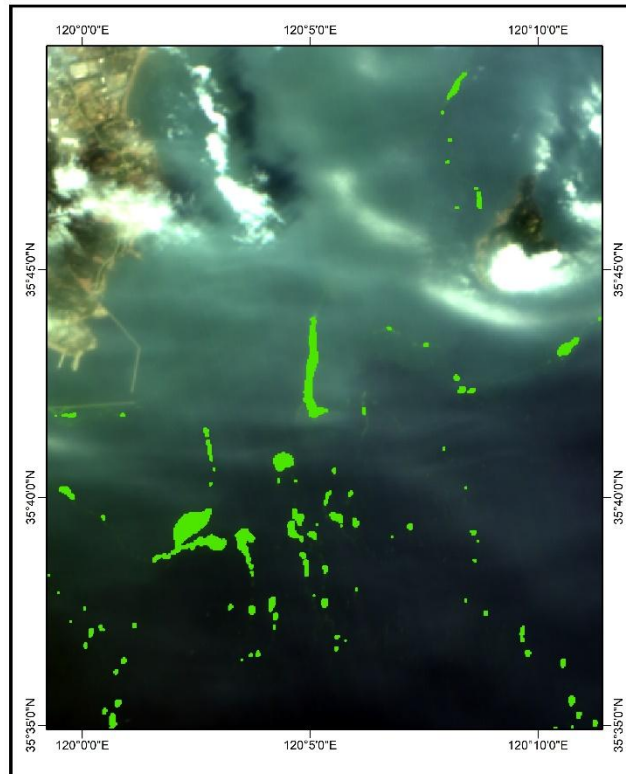

遥感卫星: HY-1D  
坐标系: CGCS2000  
覆盖面积: —  
分布面积: —  
接收时间: 2020年07月06日13时  
制作单位: 国家卫星海洋应用中心

卫星遥感绿潮监测灰度图

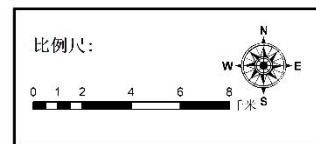
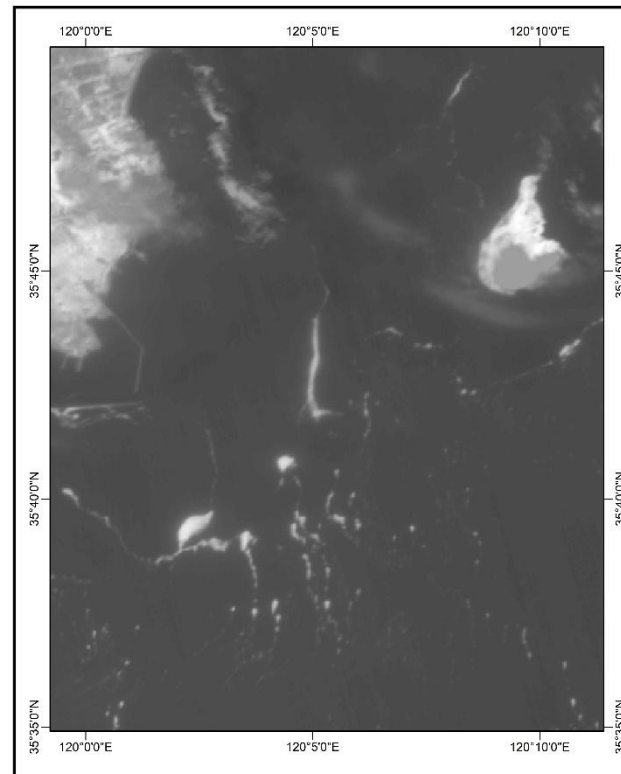

遥感卫星: HY-1D  
坐标系: CGCS2000  
覆盖面积: —  
分布面积: —  
接收时间: 2020年07月06日13时  
制作单位: 国家卫星海洋应用中心

卫星遥感绿潮监测伪彩色增强图

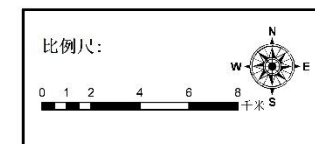
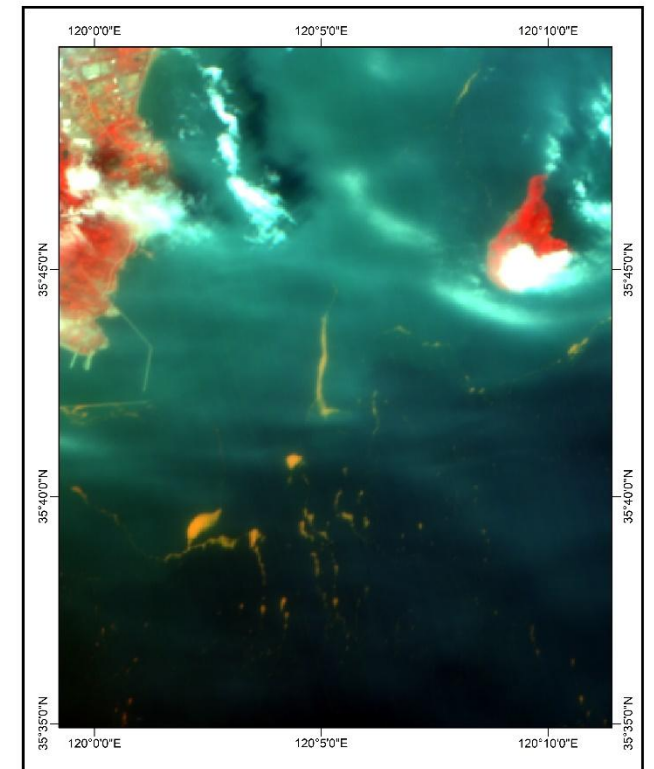

遥感卫星: HY-1D  
坐标系: CGCS2000  
覆盖面积: —  
分布面积: —  
接收时间: 2020年07月06日13时  
制作单位: 国家卫星海洋应用中心

卫星遥感马尾藻监测灰度增强图

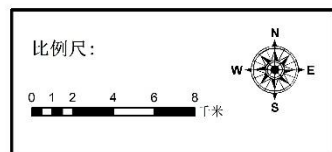
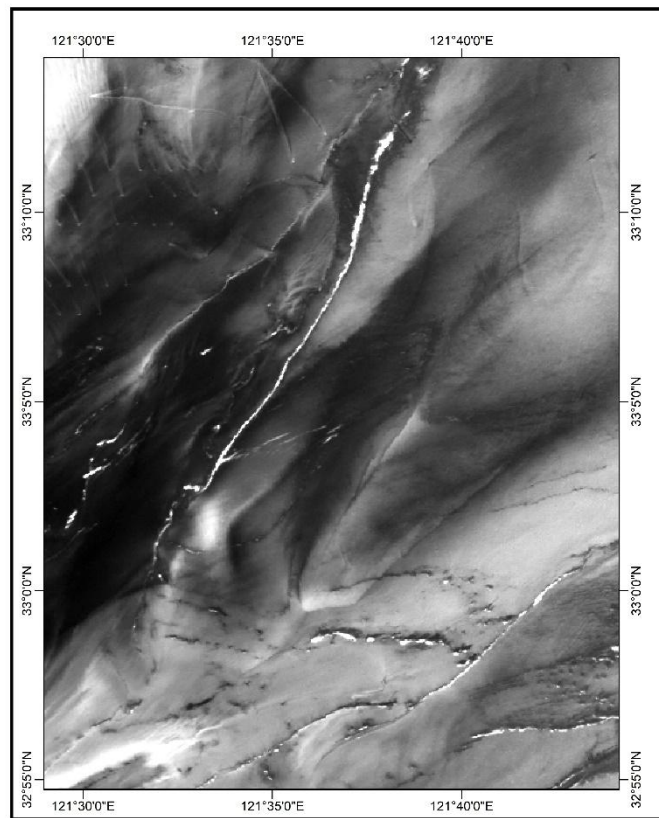

遥感卫星: IIY-1D  
 坐标系: CGCS2000  
 覆盖面积: —  
 分布面积: —  
 接收时间: 2021年05月5日13时  
 制作单位: 国家卫星海洋应用中心

卫星遥感马尾藻监测伪彩色增强图

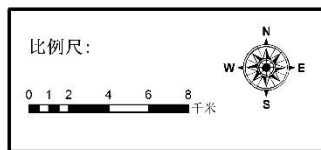
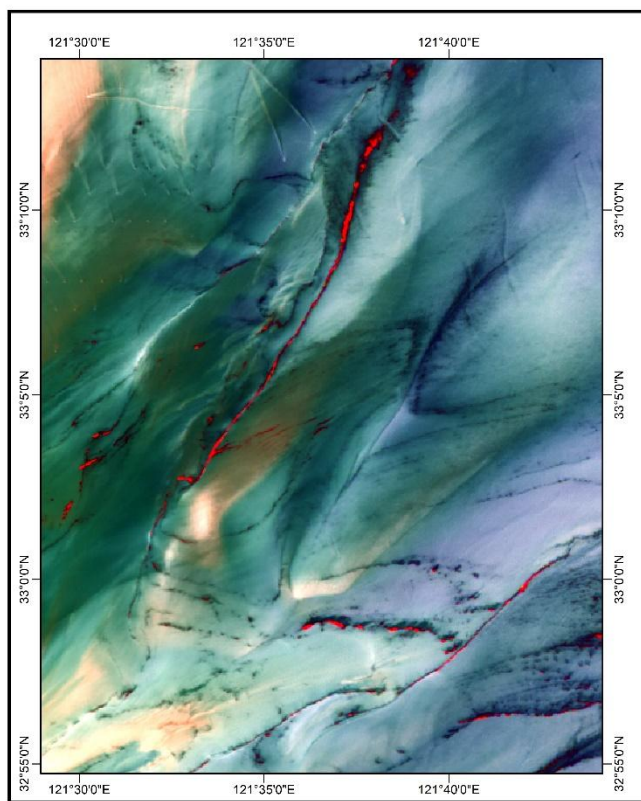

遥感卫星: IIY-1D  
 坐标系: CGCS2000  
 覆盖面积: —  
 分布面积: —  
 接收时间: 2021年05月5日13时  
 制作单位: 国家卫星海洋应用中心

卫星遥感大型藻类监测影像增强图

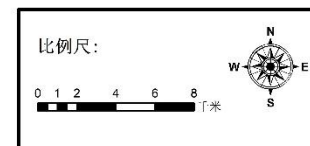
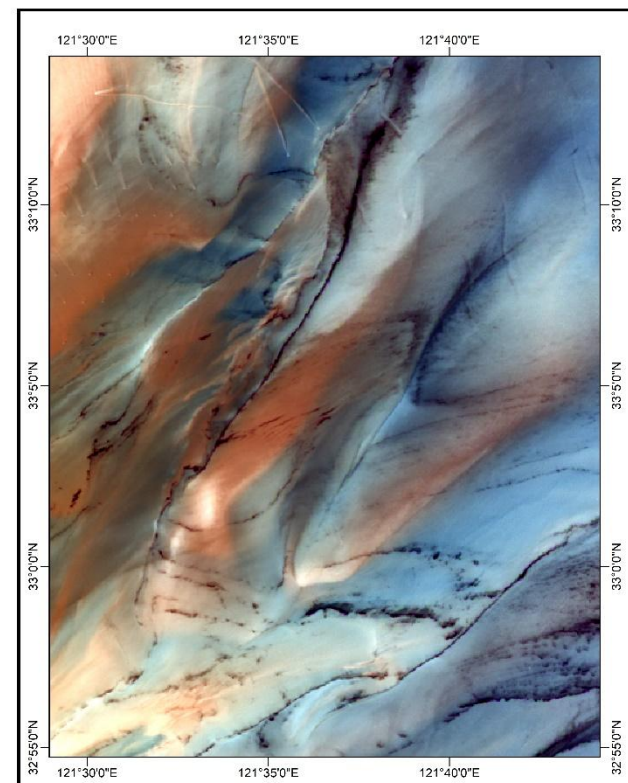

遥感卫星: HY-1D  
 坐标系: CGCS2000  
 覆盖面积: —  
 分布面积: —  
 接收时间: 2021年05月5日13时  
 制作单位: 国家卫星海洋应用中心

Spectral Profile

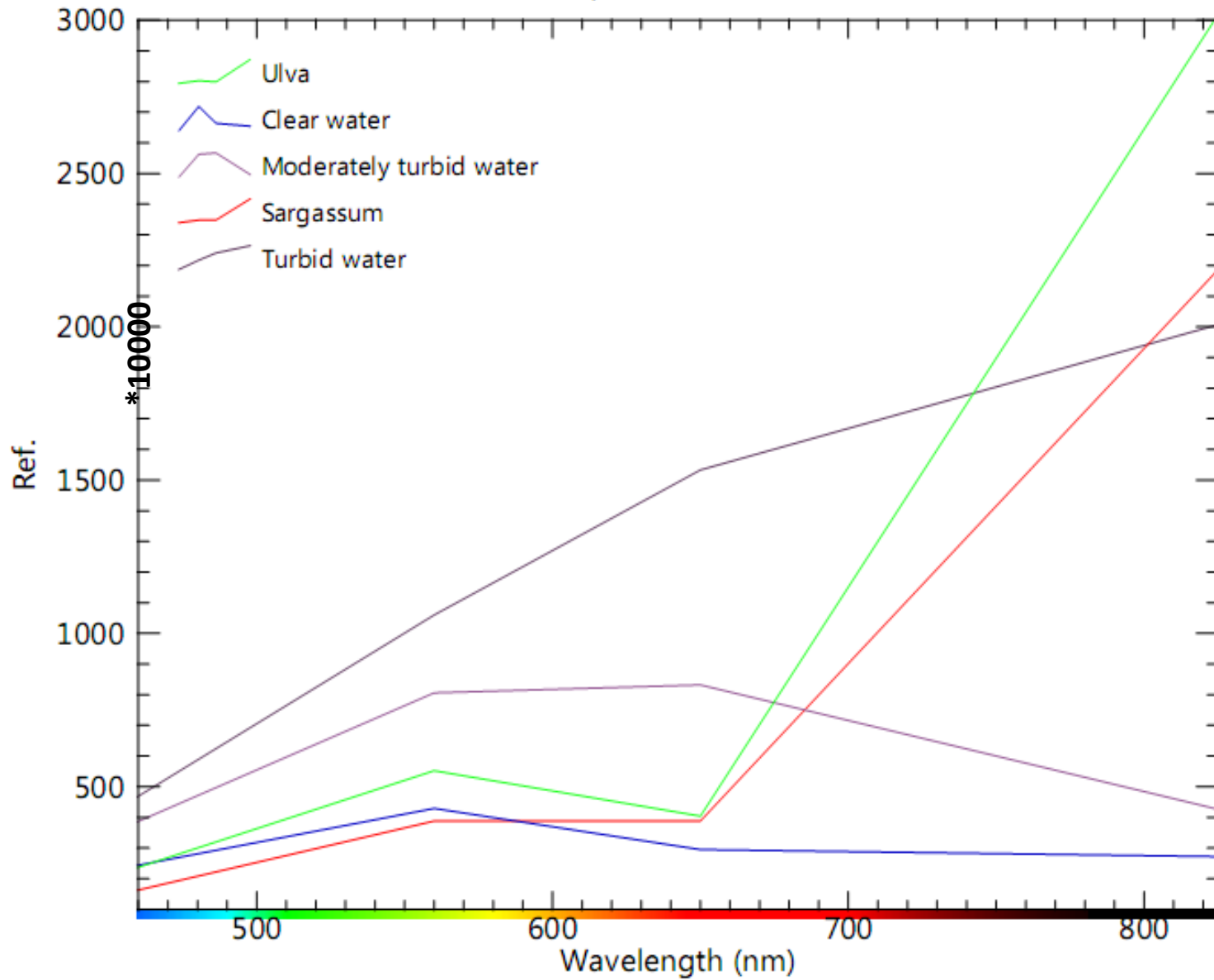

浒苔

Enteromorpha

马尾藻

Gulfweed

浑浊海水

中等浑浊海水

清洁海水



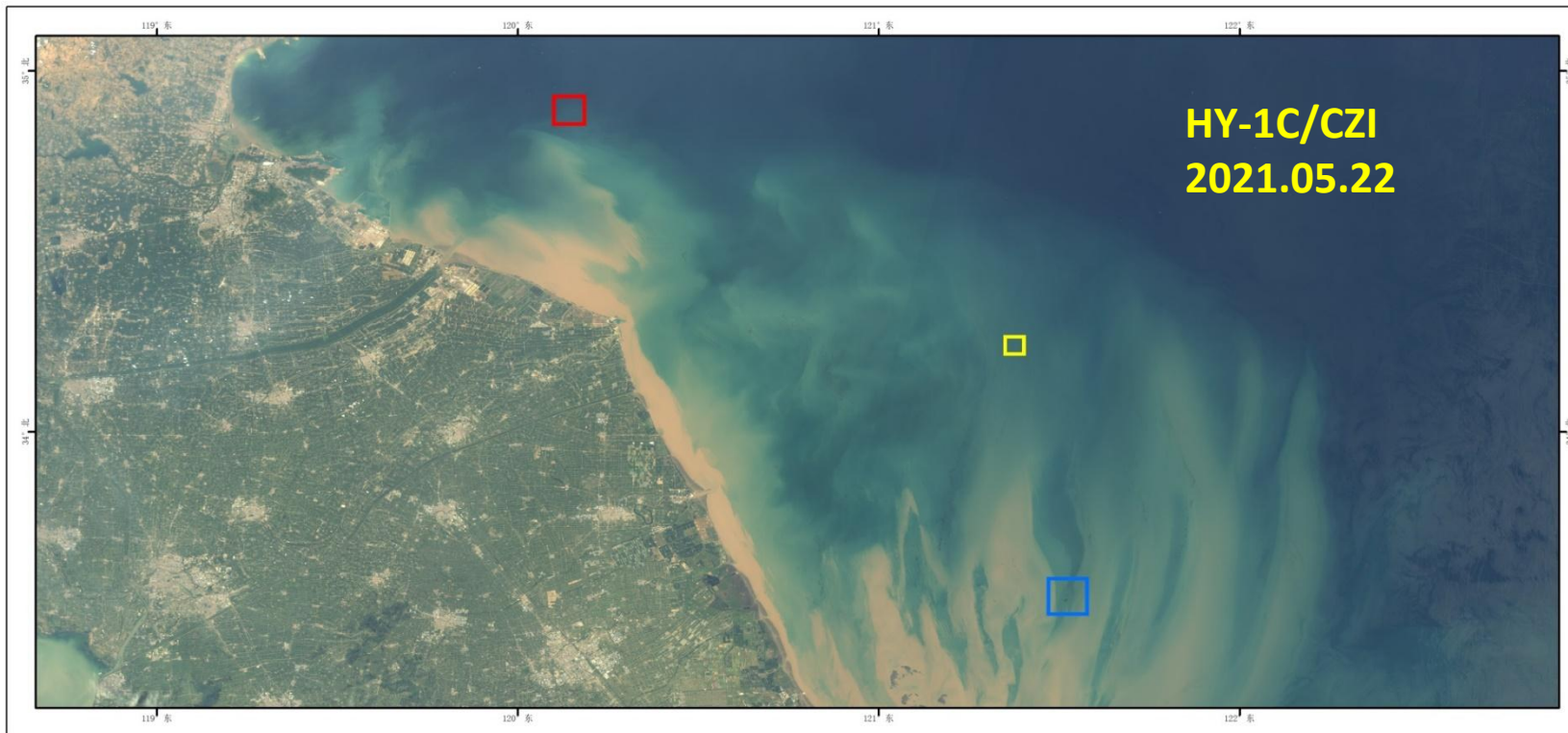

浒苔  
**Enteromorpha**



浒苔马尾藻混合  
**Enteromorpha & Gulfweed**



马尾藻  
**Gulfweed**

哨兵卫星马尾藻监测影像图

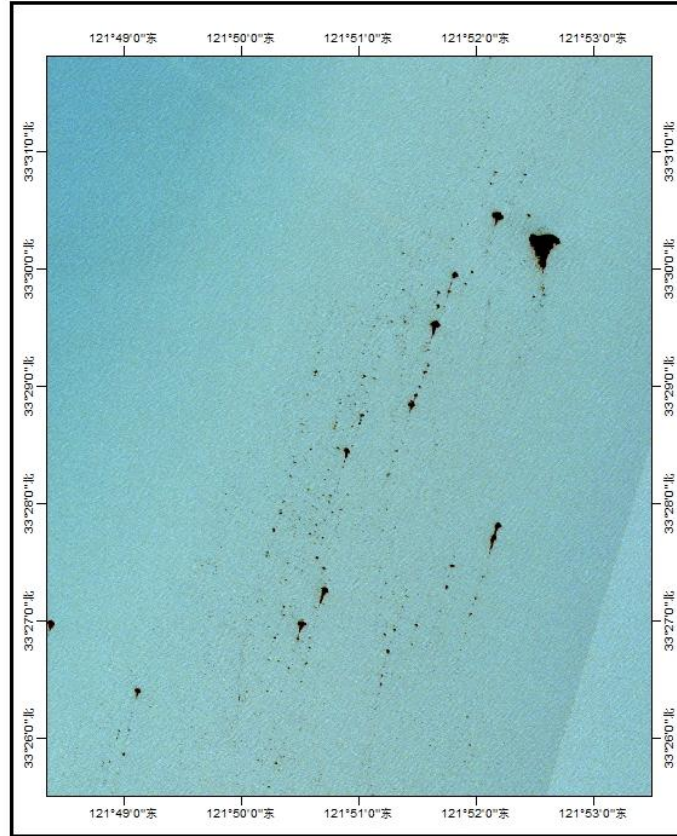

Gulfweed monitoring by Sentinel  
satellite

Enteromorpha cover  
area 25 km<sup>2</sup>

大型藻类遥感监测分布图

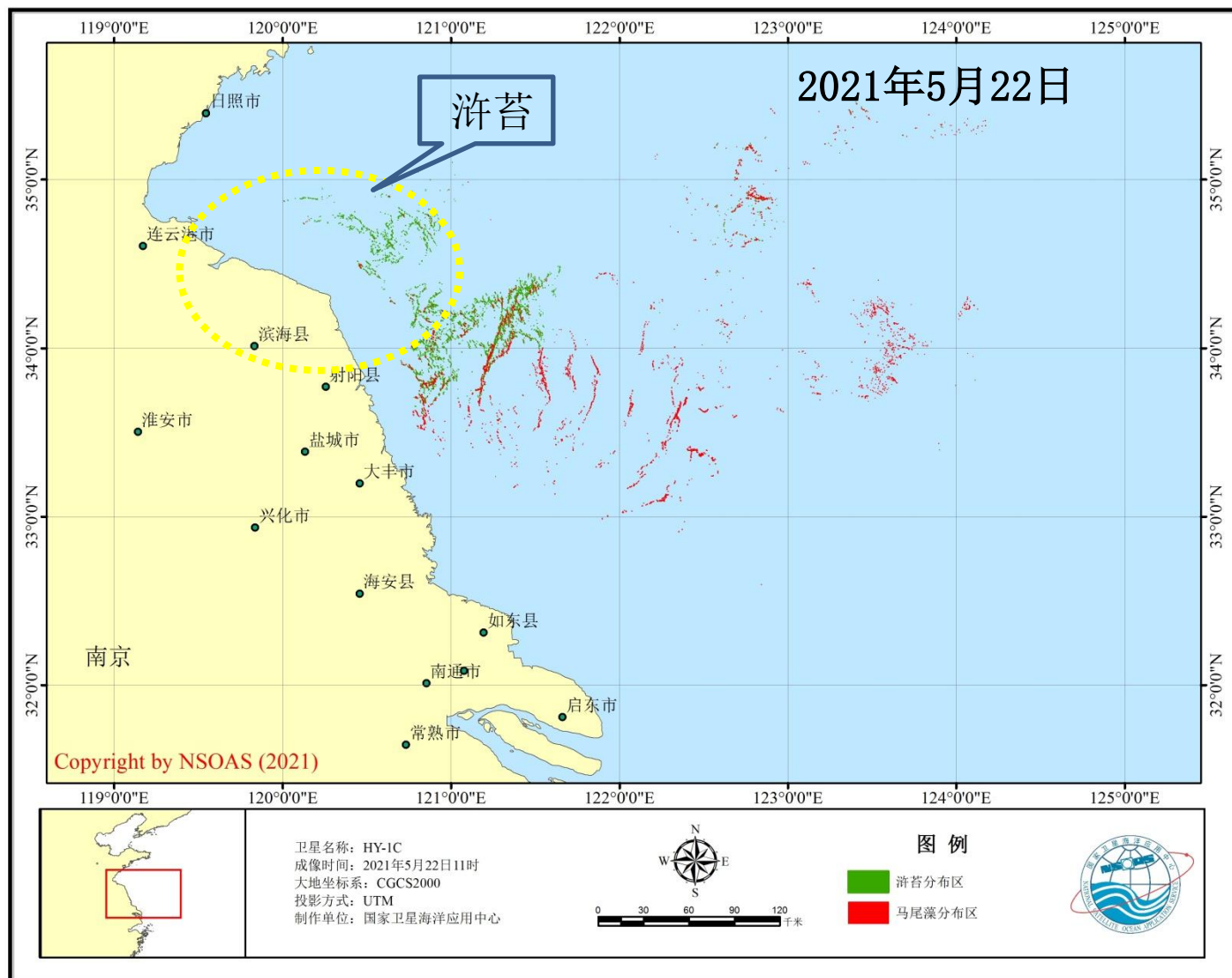

# 海洋一号D卫星东海赤潮遥感影像图

Red tide

*Noctiluca scintillans*

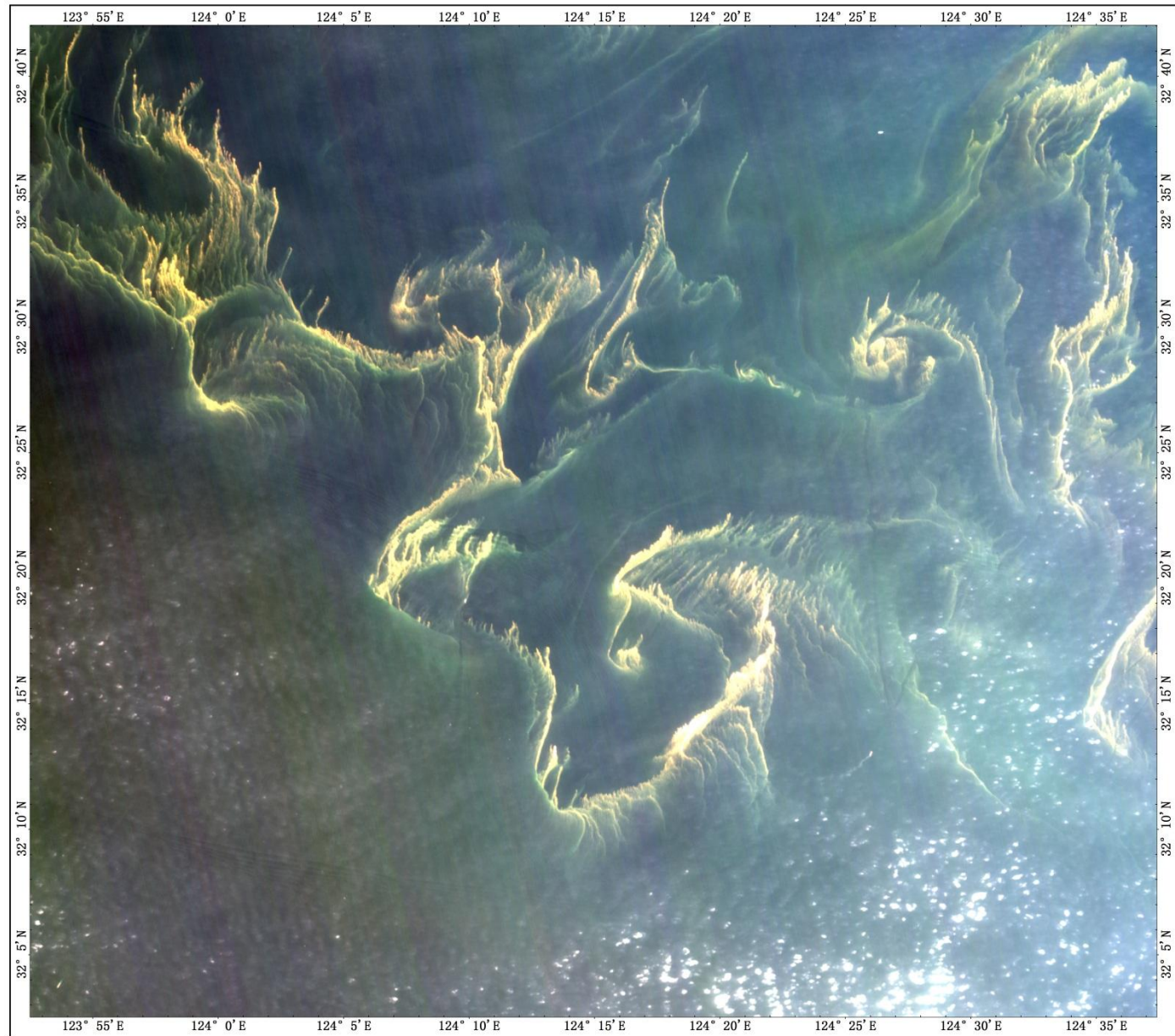

载荷: CZI/海岸带成像仪 成像时间: 202008171309

0 5 10 千米

自然资源部国家卫星海洋应用中心

# 海洋一号C卫星印度尼西亚近海遥感影像图

Oil spill

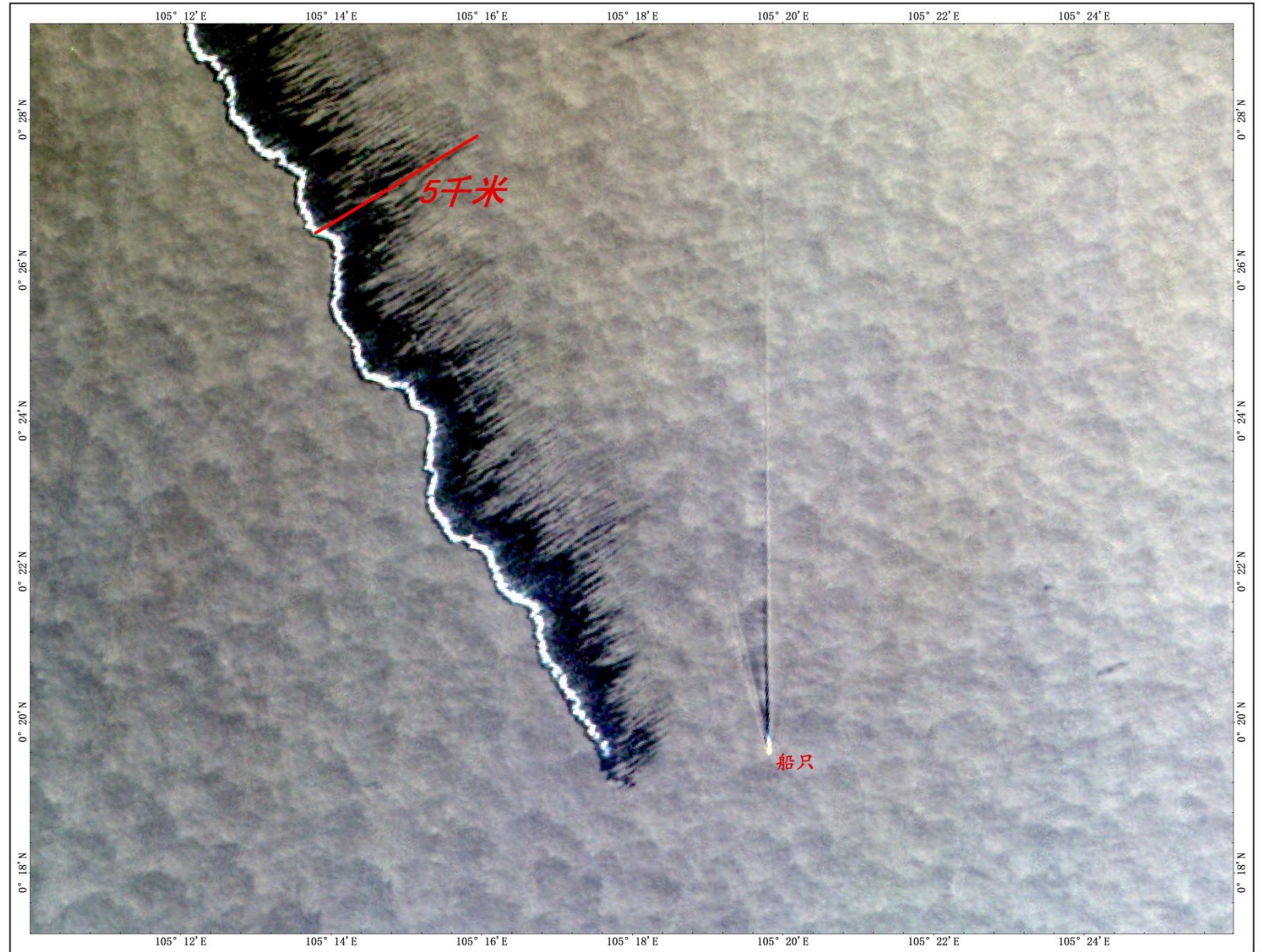

自然资源部国家卫星海洋应用中心 刘建强制作

1:20,000 CGSC2000 1 5 0 1 2 3 4 千米

卫星/载荷: HY-1C/CZI海岸带成像仪  
成像时间: 2020年04月20日03:33UTC



# 6 Next plan

Validation and compare

information extraction and mix together (fuse)

Time series data (information) / big data display and research

Thank you !